

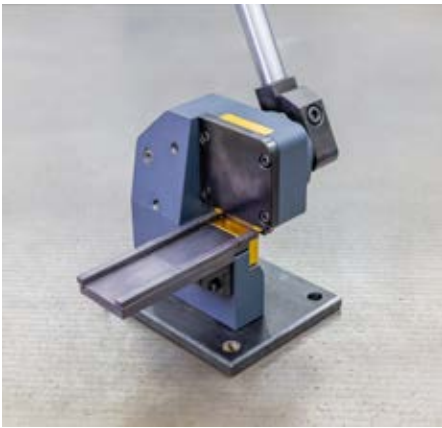

MARBACH

**MATERIALS & EQUIPMENT FOR
PACKAGING PRODUCERS.**

**PACKAGING.
PERFORMANCE.
YOU.**



MATERIALS & EQUIPMENT. SUITABLE FOR EVERYONE.

Marbach produces tools for the global packaging industry: Cutting dies, stripping and blanking tools for paperboard and corrugated board production. What many do not know: Marbach Die Supplies also offers a comprehensive range of materials and equipment.

The product portfolio of Marbach Die Supplies is very wide-ranging. It offers the right solution for every requirement.

From A like aluhammer. Over C as in channel grooves. F like finishing tape. To R like rubber strips. At Marbach, we have numerous materials and tools in our product range that are needed by a packaging producer.

The product range also includes Marbach developments that make your daily work easier: Nick setters, small tools, rule pullers, pliers, measuring devices as well as original spare parts for the maintenance of your tools. But also in-house developments such as mpower cutting rules or marbastrip claws are available from us. As a Marbach customer you will not only benefit from materials meeting your requirements but also from individual advice by your Marbach experts.

Use the materials of Marbach. Benefit from the decades of experience of the world market leader. For best performance in the production of your packaging.

All products from our catalog are available at Marbach Die Supplies: supplies@marbach.com.

Notes regarding this catalog:

Packaging units are subject to change | Marbach General Terms and Conditions apply (marbach.com/en/daten/general-terms-and-conditions) | Pictures without guarantee | Item properties may vary | Further items and designs on request.

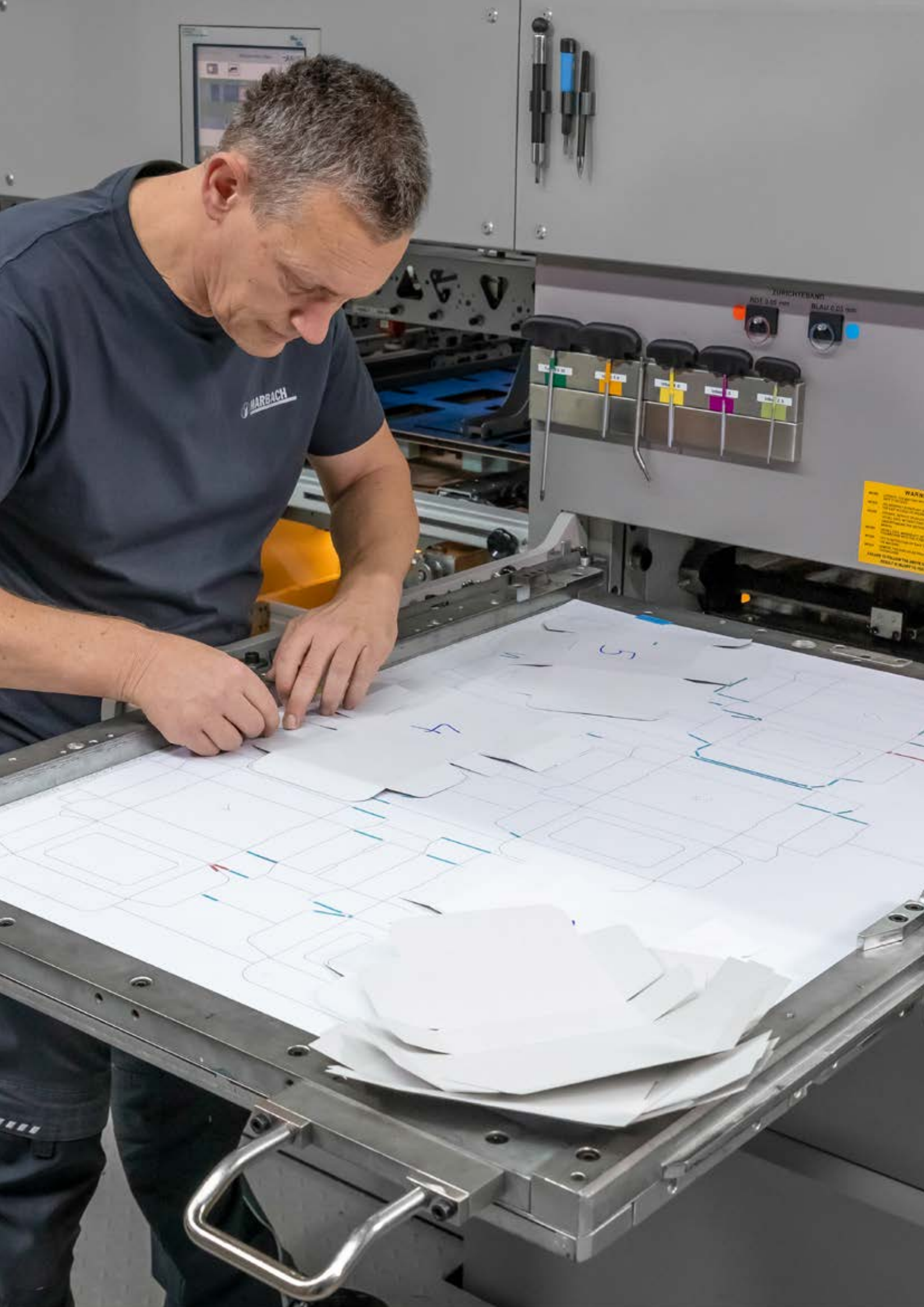

| | |
|--|-----------|
| Make-ready materials | 6 |
| Counter plates | 8 |
| rillma + | |
| Cutting plates | |
| Cutting chase cover plates | 12 |
| Digital zone levelling & mplatten cleaner | 13 |
| Nicks | 14 |
| Grinding discs | |
| Nick grinder | |
| marbanick 2+ | |
| Nick-changing-system | |
| Handheld devices | 16 |
| mcut multi | |
| mbend | |
| mcut round | |
| mcut matrix | |
| mrule extractor | |
| Workbenches, lamps & trimknife | 18 |
| Tools | 20 |
| Knifing | 22 |
| Cutting rules | |
| Creasing rules | |
| Perforation rules. Combo perforation rules | |
| Tear perforation rules | |
| Special rules | |
| Punches | 34 |
| Rubbering corrugated | 36 |
| Flat cutting | |
| Rotary cutting | |
| Rubbering paperboard | 40 |
| Accessories | |
| Embossing | 42 |
| Crease plates | 43 |
| Braille | 44 |
| Steel and wooden bar | 45 |
| Stripping | 46 |
| Blanking | 48 |
| Logistics | 50 |
| MDSS | |
| Quality control | 52 |
| Crease bend tester | |
| marbapress | |
| Sample cutter | |
| Hydraulic press | |



MAKE-READY MATERIALS. SELF-ADHESIVE TAPES.

Make-ready tape, paper

| Name | Item no. | Version | PU |
|--------|----------|------------------------|---------|
| blue | 03030 | 30 μ , 3 mm width | 40 pcs. |
| blue | 05830 | 30 μ , 6 mm width | 25 pcs. |
| blue | 12030 | 30 μ , 12 mm width | 12 pcs. |
| red | 03050 | 50 μ , 3 mm width | 40 pcs. |
| red | 05850 | 50 μ , 6 mm width | 25 pcs. |
| red | 12050 | 50 μ , 12 mm width | 12 pcs. |
| yellow | 03080 | 80 μ , 3 mm width | 40 pcs. |
| yellow | 05880 | 80 μ , 6 mm width | 25 pcs. |
| yellow | 12080 | 80 μ , 12 mm width | 12 pcs. |

Make-ready tape, stainless steel

| Name | Item no. | Version | PU |
|-----------------|----------|--------------------------|-----------|
| stainless steel | 07399 | 30 μ , 6,5 mm width | 10 m/roll |
| stainless steel | 07401 | 50 μ , 6,5 mm width | 10 m/roll |
| stainless steel | 07402 | 100 μ , 6,5 mm width | 10 m/roll |

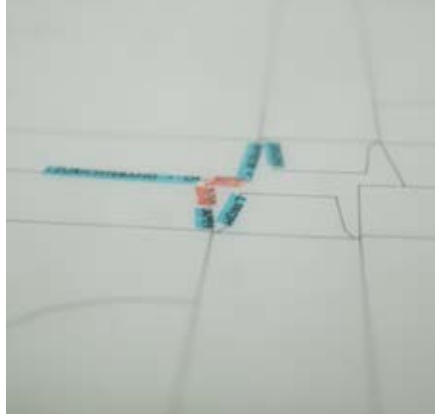

MAKE-READY MATERIALS. TECHNICAL PAPERS.

Make-ready paper

| Item | Item no. | Type | Version | PU |
|-------------------|----------|--------|---------------------------|------------|
| silk paper, white | 09735 | sheets | 30 μ , 100 cm x 75 cm | 1,000 pcs. |

Make-ready sheets, plotter foil and carbon paper

| Item | Item no. | Type | Version | PU |
|-----------------------------|----------|------------|-----------------------------|------------|
| make-ready sheet, 3-layers | 14412 | 50 m roll | 100 μ , 122 cm width | 1 pc. |
| make-ready sheet, 2-layers | 14432 | 30 m roll | 145 μ m, 152.4 cm width | 1 pc. |
| plotter foil, one side matt | 00591 | 30 m roll | 90 μ , 122 cm width | 1 pc. |
| one-time carbon paper | 07060 | 950 m roll | 74.5 cm width | 1 pc. |
| one-time carbon paper | 17050 | sheets | 430 x 610 mm | 1,000 pcs. |



COUNTER PLATES.

rillma|+

| Pertinax material rillma + * | | |
|--------------------------------------|----------|---------|
| Full format (1,070 mm x 1,070 mm) | | |
| Thickness | Item no. | PU |
| 0.30 mm | 09645 | 1 plate |
| 0.40 mm | 09646 | 1 plate |
| 0.45 mm | 09643 | 1 plate |
| 0.50 mm | 09647 | 1 plate |
| 0.55 mm | 09681 | 1 plate |
| 0.60 mm | 09650 | 1 plate |
| 0.65 mm | 09602 | 1 plate |
| 0.70 mm | 09651 | 1 plate |
| 0.75 mm | 09644 | 1 plate |
| 0.80 mm | 09652 | 1 plate |

| Pertinax material rillma + * | | |
|------------------------------------|----------|---------|
| Half format (1,070 mm x 535 mm) | | |
| Thickness | Item no. | PU |
| 0.30 mm | 09653 | 1 plate |
| 0.40 mm | 09654 | 1 plate |
| 0.45 mm | 09683 | 1 plate |
| 0.50 mm | 09655 | 1 plate |
| 0.55 mm | 09810 | 1 plate |
| 0.60 mm | 09656 | 1 plate |
| 0.65 mm | 09611 | 1 plate |
| 0.70 mm | 09657 | 1 plate |
| 0.75 mm | 09615 | 1 plate |
| 0.80 mm | 09658 | 1 plate |

*without adhesive film; item available with adhesive film

Accessories for rillma and steel counter plates

| Item | Item no. | Version | PU |
|------------------------------|----------|---|------------|
| rillma pin standard | 07094 | 5x18 mm; bevel max. 0.5 mm double-sided | 1,000 pcs. |
| rillma pin plastic | 08919 | head Ø5.5 mm; base Ø8 mm; 18 mm long | 100 pcs. |
| mecosol glue spray universal | 07093 | 500 ml bottle | 1 pc. |
| puller | 07067 | 200 mm, grinded | 1 pc. |
| puller | 07156 | 200 mm, standard | 1 pc. |
| steel counter plate socket | 15013 | for multiplex dies | 100 pcs. |
| steel counter plate socket | 14312 | for duramar dies | 100 pcs. |
| spring pins | 07085 | Ø6 mm x 20 mm, lightweight | 500 pcs. |
| moose rubber rings** | 07088 | light grey, extra strong, Ø6 mm x 5 mm | 1,190 pcs. |
| laminating film rillma | 43027 | roll 50 m x 1,050 mm x 40 µm | 1 pc. |

**further rubber rings on request

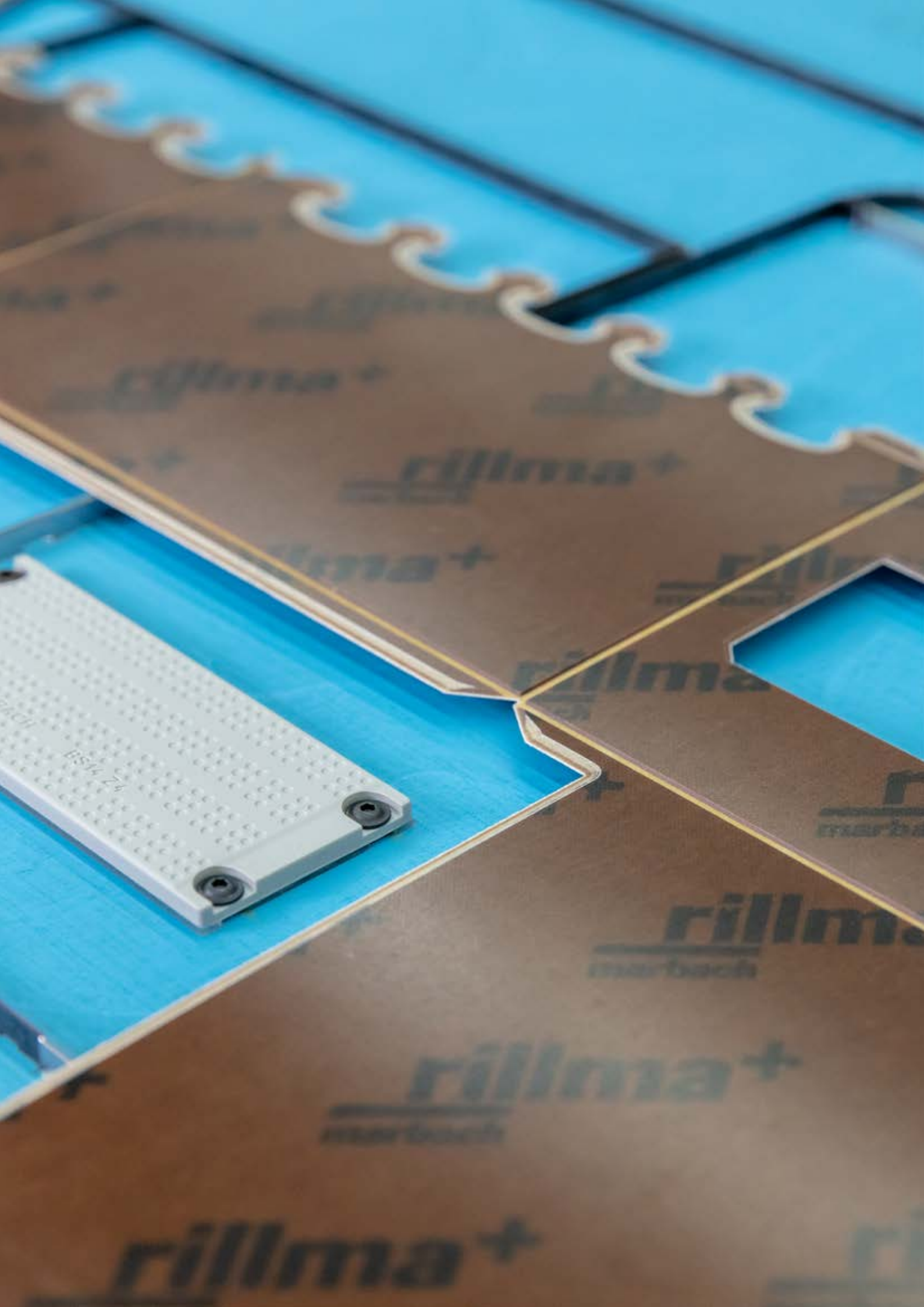





COUNTER PLATES. CUTTING PLATES.

We cut cutting plates to the contour you require. Suitable for one or more machines. Marbach cutting plates are available in different designs and degrees of hardness. Medium hard (35 HRC) and hard (48 HRC), in different thicknesses. For every requirement.

Packaging unit medium hard plates: 10 pcs. | Packaging unit hard plates: 5 pcs.

Further versions as well as milled steel counter plates on request.

Paperboard processing machines

Item no.

| | |
|-----|--------|
| 76 | M-4900 |
| 102 | M-4900 |
| 104 | M-4900 |
| 106 | M-4900 |
| 130 | M-4900 |
| 142 | M-4900 |
| 145 | M-4900 |
| 162 | M-4900 |

Corrugated board processing machines

Item no.

| | |
|------|--------|
| 1600 | M-4900 |
| 1700 | M-4900 |
| 2000 | M-4900 |
| 2100 | M-4900 |

Further sizes on request at supplies@marbach.com.



CUTTING CHASE. COVER PLATES.

With the cutting chase cover plates, you protect your make-ready sheet. And ensure optimum conditions in your platen area. For minimum make-ready times and maximum productivity.

| Machine | Item no. | Thickness |
|---------|----------|-----------|
| 102 | M-0750 | 1 mm |
| 104 | M-0750 | 1 mm |
| 106 | M-0750 | 1 mm |
| 130 | M-0750 | 1 mm |
| 142 | M-0750 | 1 mm |
| 145 | M-0750 | 1 mm |
| 162 | M-0750 | 1 mm |
| 1600 | M-0750 | 6 mm |
| 1700 | M-0750 | 6 mm |
| 2000 | M-0750 | 6 mm |
| 2100 | M-0750 | 6 mm |

Accessories

| Item | Item no. |
|---|----------|
| Special bio cleaner (600 ml) for cutting chase cover plate "digital zone levelling" | 07193 |

Digital zone levelling.

MAKE-READY TIME REDUCTION.

Compensation of machine-related tolerances

No zone make-ready necessary

Quick and easy to implement

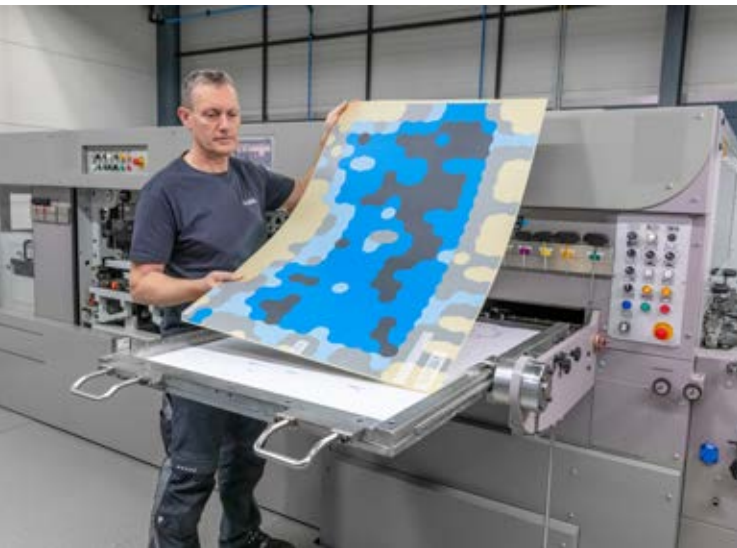

The die-cutting machine is subject to tolerances caused by wear and tear. For this reason, it was previously necessary to fill worn out zones with make-ready paper when setting up an order. This effort was required for every single order. With digital zone levelling, the process is much more efficient. This zone make-ready only needs to be done once. And then holds on for months to come.

| Item no. | Machine |
|----------|---------|
| M-0770 | 76-106 |
| M-0770 | 130-145 |
| M-0770 | 162 |
| M-0770 | 1600 |
| M-0770 | 1700 |
| M-0770 | 2000 |
| M-0770 | 2100 |

Increased machine productivity

Shorter make-ready times

Easy handling



mplatten|cleaner.

CLEAN DIE-CUTTING.

For maximum output when die-cutting. The mplatten|cleaner is a device for cleaning the die cutting machine platen. This enables the machine operator to clean the platen efficiently and increase the productivity of the machine. The mplatten|cleaner is easy to handle and inexpensive to purchase. Suitable for all flatbed corrugated board machines and various paperboard machines.

| Item no. | Version |
|----------|------------------|
| G-2254 | mplatten cleaner |
| 900246 | cleaning pads |
| 900247 | grinding pads |



NICK GRINDING. GRINDING DISCS.

For the use of a nick grinder you need the appropriate grinding discs. Diamond for a long lifetime. Or the cheaper version mafix, for variety in all sizes. Our grinding discs are available with different hole diameters.

| Grinding discs | mafix (50 mm/6 mm hole diameter) | Diamond (50 mm/6 mm hole diameter) |
|-----------------------|--|--|
| Thickness | Item no. | Item no. |
| 0.2 mm | 07002 | 912242 |
| 0.3 mm | 07003 | 912243 |
| 0.4 mm | 07004 | 912244 |
| 0.5 mm | 07005 | 912245 |
| 0.6 mm | 07006 | 912246 |
| 0.7 mm | 07007 | 912247 |
| 0.8 mm | 07008 | 912248 |
| 0.9 mm | 07009 | 912249 |
| 1.0 mm | 07010 | 912250 |
| 1.1 mm | 07011 | 912251 |
| 1.2 mm | 07012 | 912252 |
| 1.3 mm | 07013 | 912253 |
| 1.4 mm | 07014 | 912254 |
| 1.5 mm | 07015 | 912255 |
| 1.6 mm | 07016 | 912256 |
| 1.7 mm | 07017 | 912257 |
| 1.8 mm | 07018 | 912258 |
| 1.9 mm | 07019 | 912259 |
| 2.0 mm | 07020 | 912260 |
| 2.5 mm | 07025 | 912261 |
| 3.0 mm | 07000 | 912262 |

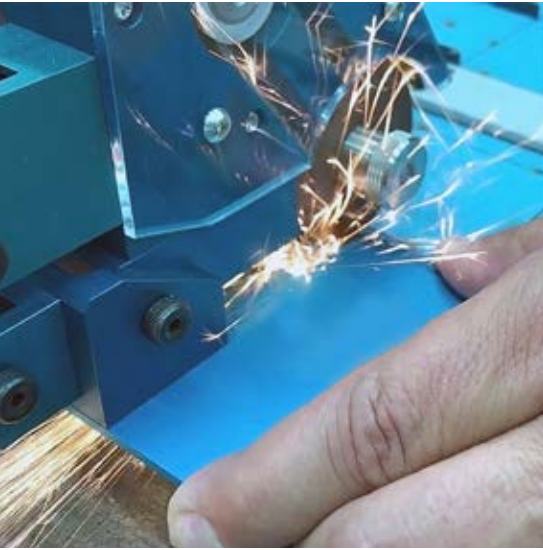

Nick grinder.

THE EFFECTIVE ONE.

Transport nicks should be ground in. We have the right solution for every requirement.

| Item no. | Name |
|------------|--------------------------|
| G-2135 | nick grinder battery |
| G-2143 | nick grinder electric |
| G-2134 | spare battery for G-2135 |
| on request | depth adjustment |

further nick grinders available on request



marbanick|2+.

THE FAST ONE.

For the subsequent optimization of waste nicks, the marbanick|2+ is the optimal solution. With its different impact levels, it combines the functionality of 3 devices in one. And impresses with its integrated quick-change function. And four different wedge sizes (0.3, 0.4, 0.5 and 0.6 mm). These features make the marbanick|2+ extremely flexible and cost-efficient.

| Item no. | Name |
|----------|--------------|
| 34162 | marbanick 2+ |



Nick changing system.

THE FLEXIBLE ONE.

Flexibility is important when it comes to nicks. That's what the nick changing system for corrugated applications is for. With it, a cutting die can be perfectly set-up for different material characteristics in the least possible time.

Note: Special preparation of the cutting die is necessary.

| Item no. | Name |
|----------|--|
| 04900 | nick changing system case with accessories for flat corrugated |
| 04900 | nick changing system case with accessories for rotary corrugated |

mcut|multi.

THE ALLROUNDER.



An indispensable handheld device. 3 devices in one. Multi-functional and with digital gauge. The mcut|multi can not only cut rules, but also lips. And it can also notch. For rule materials from 2pt to 3pt. It cuts steel quickly and without deformation. And it does so with a very small footprint.

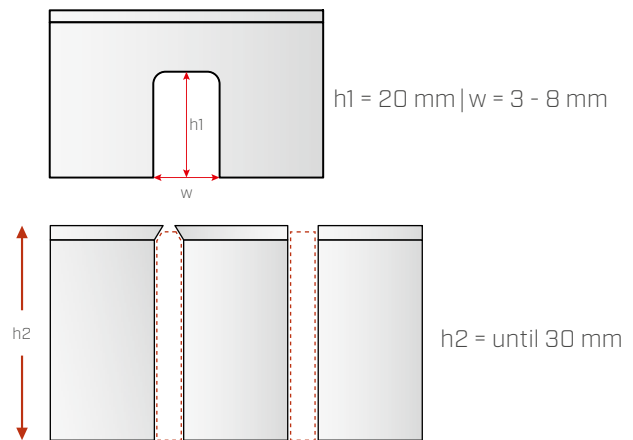

| Item no. | Name |
|----------|------------|
| G-2920 | mcut multi |

mbend.

THE MANIFOLD.



The mbend. A manual bending device for optimum bending processes. And for precisely bent rules. Robust, variable and easy to handle. For line thicknesses from 1.5 to 4pt. And line heights from 8 to 50 mm. With an extensive range of standard bending forms. With the special scale, depth setting is quick and accurate. The possibility of locking ensures precise repeatability.



| Item no. | Name |
|----------|-------|
| G-2330 | mbend |



mcut|round.

THE DEFINED ONE.

Simple and clever. That is the mcut|round. This special hand-held device rounds off the ends of flat or rotary creasing rules in a defined manner. In consistent quality, from the first to the last creasing rule. This prevents the paperboard from bursting at the creasing ends. The mcut|round cuts radii of 3 or 5 mm. Its cutting elements are wear-resistant, and repeated regrinding is possible. The mcut|round stands for high durability and best creasing performance.

| Item no. | Name |
|----------|------------|
| G-2730 | mcut round |



mcut|matrix.

THE PRECISE ONE.

The mcut|matrix cuts creasing matrix. Fast, precise and safe. It is a flexible, ergonomic, very robust hand-held device that is perfectly adapted to the conditions in production. The infinitely variable gauge can be used for a wide variety of creasing geometries. Thus, it not only ensures exact cutting results, but also maximum flexibility. The special design of the mcut|matrix ideally reduces the required cutting force. For little effort when cutting creasing matrix.

| Item no. | Name |
|----------|-------------|
| G-2740 | mcut matrix |



mrule|extractor.

THE SAFE ONE.

The rule puller mrule|extractor is indispensable as an effective helper on the die-cutting machine. It is used whenever damaged knives need to be safely removed from a cutting die and replaced with spare knives. With the mrule|extractor, rules are drawn easily, in a controlled, precise and safe manner. Safe for the user and safe for the cutting die. The optimum pre-requisite for a perfect fit of the replacement knives.

| Item no. | Name |
|----------|-----------------|
| G-3300 | mrule extractor |

mbench|smart. THE CLEVER ONE.



| | |
|----------------------------|--|
| Item no.: | G-2180 |
| Dimensions (lxwxh): | 1,500x700x1,100 mm (Back panel: 1,500 mm) |
| Drawers: | 5 pcs., width > 1,000 mm |
| Rear wall: | with 6 shelves |
| Work surface: | anti-slip rubberized surface |
| Wheels: | lockable heavy duty wheels |

Maximum flexibility and efficiency: With the mobile repair workstation mbench|smart you will be prepared for all situations. For reworking the cutting die, e.g. directly at the die-cutting machine. Its smooth-running heavy-duty wheels ensure safe and quick transport to its place of use. Due to the optional equipment with important rule processing devices such as the hand bender mbend or the multifunctional device mcut|multi for cutting to length, notching and lipping, it will become an indispensable companion in your production. The 5 integrated drawers offer plenty of space for your accessories. The rear panel includes 6 shelves for different cutting rules, easily accessible via a central access opening.

mbench|smart. Your mobile companion for fast and cost-saving on-site repair of your tools.



| | |
|----------------------------|--|
| Item no.: | G-2181 |
| Dimensions (lxwxh): | 1,340x1,340x1,000 mm |
| Drawers: | 9 pcs., width > 1,000 mm |
| Mounting plate: | 700x1,000 mm |
| Work surface: | steel plate and anti-slip rubberized surface |
| Wheels: | lockable heavy duty wheels |

mbench|pro. THE UNIVERSAL ONE.

mbench|pro. The professional assembly table for your tool preparation. It is larger than the mbench|smart. And even more versatile. A complete workstation with assembly surface. In the 9 drawers you have plenty of space for accessories and important equipment for processing your cutting tools. Of course, the mbench|pro can also be equipped with the most important line processing equipment. And just like the mbench|smart, it has smooth-running heavy-duty wheels for maximum mobility.

The mbench|pro. Your mobile assembly table for maximum performance in your die preparation.

LED WORK LIGHT.

THE FLEXIBLE ONE.

High luminosity

Flexibly adjustable

Best visibility at the workplace

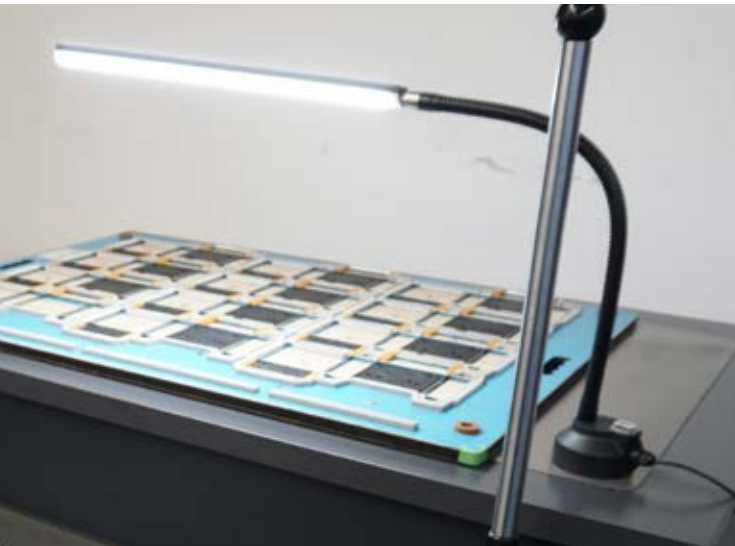

Our special LED work light provides optimum illumination of your tool processing surface. With its strong luminosity of 1,250 lumens, the LED work light is very bright. And it does so with low energy consumption. In addition, it is very flexible: because it can be magnetically attached to any place on your work table and also has an arm that can be adjusted in all directions. This means that the LED light can always be used to optimally illuminate the desired area. For the best visibility when machining your tools.

| Item no. | Name |
|----------|----------------|
| G-0000 | LED work light |

Available as single position or complete system

In 6 different heights

Including shimfoils & rubber

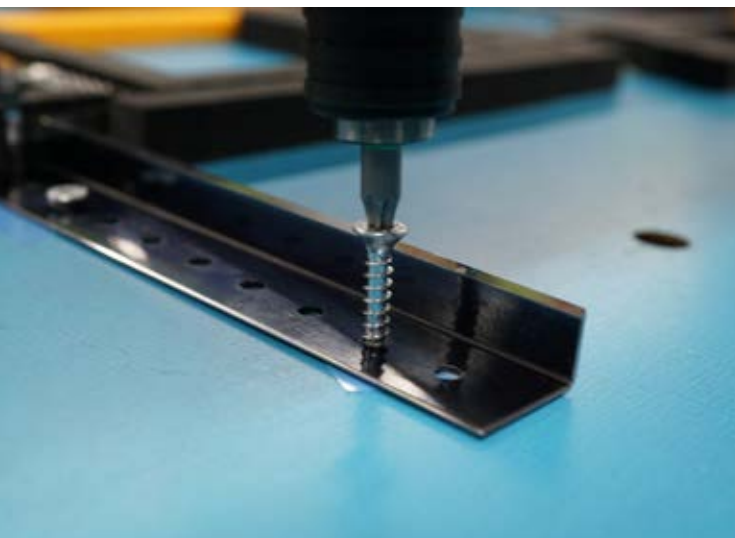

trimknife|multi.

THE SPECIAL ONE.

trimknife|multi. Screw-on cut-off knives for special requirements in 6 different heights. trimknife|multi is the solution when the waste cut-off knives of the tool need to be replaced or extended. Available as a single item (cut-off knives) or as a complete set with cut-off knives including shimfoils, fastening screws, rubber material as well as a suitable screwdriver incl. bit for a cordless screwdriver.



| Item no. | Name |
|----------|-----------------|
| 04355 | trimknife multi |

TOOLS.



Scissors

Different versions of scissors. To cut rubber easily and safely.

- combo scissors, 190 mm length [13018]
- small scissors, 160 mm length [13109]

| Item no. | Name |
|----------|----------------|
| 13018 | combo scissors |
| 13109 | scissors small |



Bevelling scissors

Special scissors to cut crease channels and rubber in the right angle. With exchangeable spare blades (PU = Pack of 5).

| Item no. | Name |
|----------|--------------------|
| 15639 | bevelling scissors |



Gripping pliers

Special gripping pliers with tip for quick and easy removal of rules or rubber. Also suitable for narrowest areas.

| Item no. | Name |
|----------|---------------------------------|
| 06099 | gripping pliers DIN ISO 9655 |



Pliers

Assembly pliers in different versions. Ideal for the assembly of cutting dies. In daily use at Marbach. The inexpensive alternative to rule pullers.

| Item no. | Name |
|----------|----------------------|
| 07067 | Assembly pliers |
| 04902 | Assembly pliers long |



marbaglue

Adhesive for applying rubber on cutting dies. Available in different versions depending on requirements: 06092 for flat paperboard dies, 06093 for rotary corrugated dies and 06094 for flat and rotary corrugated dies..

| Item no. | Name |
|----------|--------------------------------------|
| 06092 | plug cap (paperboard) 20g |
| 06093 | twist cap (corrugated board) 20g |
| 06094 | twist cap (corrugated board) 50g |



Aluminum hammer with exchangeable head

Aluminum hammer with interchangeable heads. For assembly of rules in folding carton dies. Optimal for mpower cutting rules and for creasing rules.

| Item no. | Name |
|----------|---------------------------|
| 08498 | Alu hammer Ø25 mm |
| 00234 | Set interchangeable heads |



Polyurethane hammer

Special polyurethane hammer for the assembly of rules in rotary corrugated board cutting dies. Robust, durable and for best force transmission. Very pleasant to handle due to its easy detachment from the rule.

| Item no. | Name |
|----------|------------------|
| 08986 | Ø50x125 mm 400 g |
| 10071 | Ø70x115 mm 710 g |



Rawhide hammer

Hammer with rawhide head for assembly of rules in rotary corrugated board cutting dies. Very tough. Dampens the load with every stroke. For high demands.

| Item no. | Name |
|----------|------------------|
| 08497 | Ø45x90 mm; 260g |
| 08730 | Ø52x105 mm; 380g |
| 08370 | Ø70x122 mm; 700g |



Soft face hammer

Hammer with a special soft head for the assembly of very sharp cutting rules in folding box and corrugated board cutting dies.

Easily replaceable nylon spare heads available.

| Item no. | Name |
|----------|---------------------------|
| 08366 | Soft face hammer Ø25 mm |
| 08495 | Set interchangeable heads |



Aluminum hammer

Hammer with aluminum head for mounting rules in folding box and corrugated board cutting dies. Optimally suited for mpower cutting rules and for creasing rules.

| Item no. | Name |
|----------|------------------|
| 08498 | 40x75 mm; 250 g |
| 08499 | 40x100 mm; 350 g |



Adjustment fork

Adjustment fork for exact alignment of rules at the rule joints. Simple and quick. With impact protection.

| Item no. | Name |
|----------|-----------------|
| 10200 | adjustment fork |

CUTTING RULES.

PIECE BY PIECE. OR BY THE COIL.



For perfect die cutting results, the rule material is of great importance. The selection depends on your individual requirements.

Marbach has an extensive portfolio of rule materials. For every application and for every need. Whether short or long runs. No matter what needs to be die cut: Coated or uncoated material. Plastic or foam. The right rule for every application. Meter pcs. [all item numbers with "M" at the end] for manual and roll material for machine processing.

mpower. The original.

A standard developed by Marbach. The mpower cutting rule. The trick: a rounded cutting tip that compensates tolerances and eliminates angel hair. Which is almost immune to overpressure. For the shortest make-ready times. Simply for maximum die cutting performance from the first to the last sheet.

| Item no.* | Thickness | Chamfer | PU/Roll |
|-----------|-----------|-------------------|---------|
| 01212 | 2pt | center bevel | 100 m |
| 01977 | 2pt | center bevel 42° | 100 m |
| 01986 | 3pt | center bevel | 75 m |
| 01252 | 3pt | long center bevel | 75 m |

*item also available by the meter

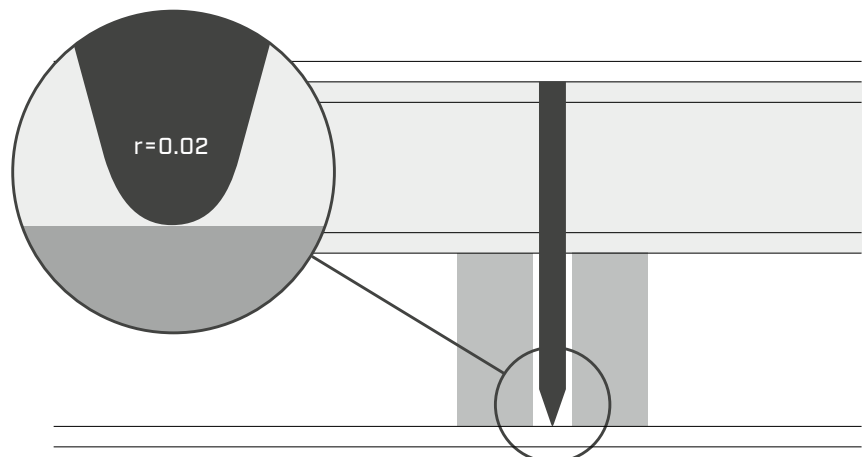

Cutting edge

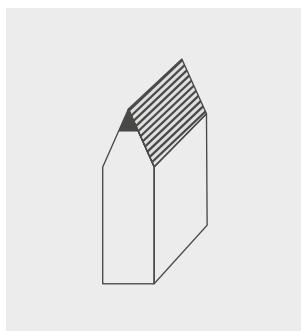

Shaved cutting edge

Precisely processed.
Reliable over many years.
The standard.

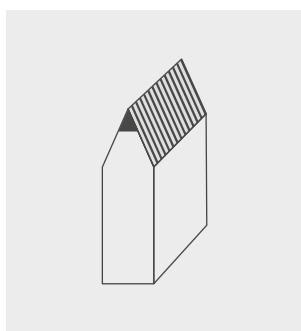

Ground cutting edge

Precise cutting edges.
Reduced cutting pressure.
Penetrates easily through the material.

Winding direction

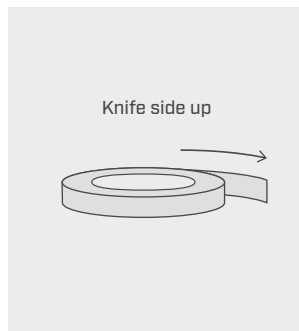

Clockwise

The correct winding direction.
For your bending machine.
And your application. Clockwise.

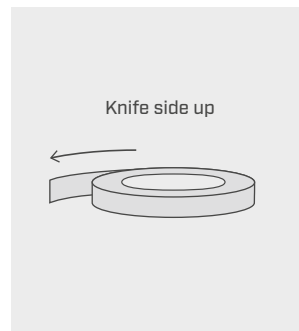

Anti-clockwise

The correct winding direction.
For your bending machine.
And your application. Anti-clockwise.

Cutting edge geometries

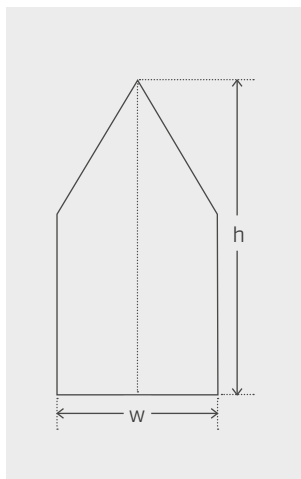

D - center bevel

The standard for cutting paperboard. Also available as side bevel.

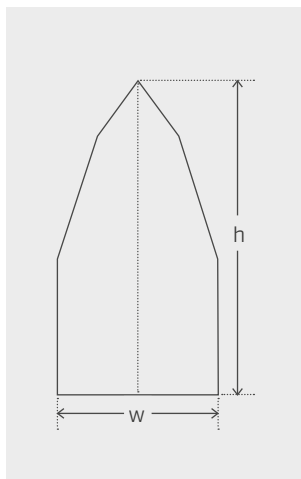

D4 - long center bevel

For thick materials. The standard for corrugated board. Also available as side bevel.

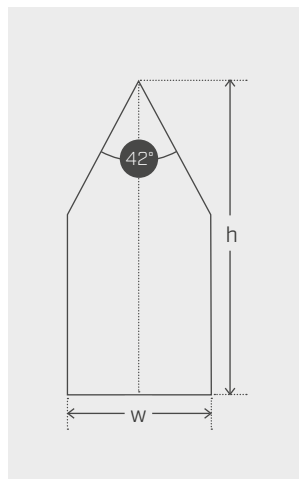

42° cutting angle

The cutting rule penetrates easily into the material. Lower cutting pressure is needed. The standard in America.

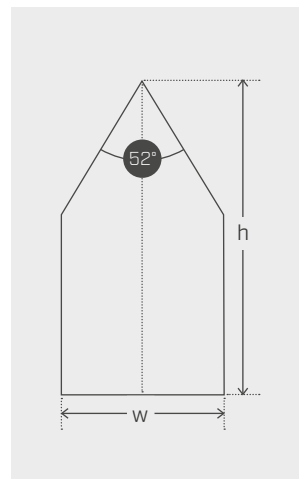

52° cutting angle

The cutting rule is very robust. It has a long lifespan. The standard in Europe and Asia.

Cutting angle

mhard.

THE HARDENED ONE.



mhard has a hardened edge. The advantages of mhard: it distinguishes itself by providing a long lifespan and high stability. With little abrasion. The mhard is a great fit for medium runs.

| Item no.* | Thickness | Chamfer | PU/Roll |
|-----------|-----------|-------------------|---------|
| 00985 | 2 pt | center bevel | 100 m |
| 01045 | 2 pt | long center bevel | 100 m |
| 02505 | 3 pt | center bevel | 75 m |
| 01073 | 3 pt | long center bevel | 75 m |

*item also available by the meter

mgold.

THE SPECIAL ONE.

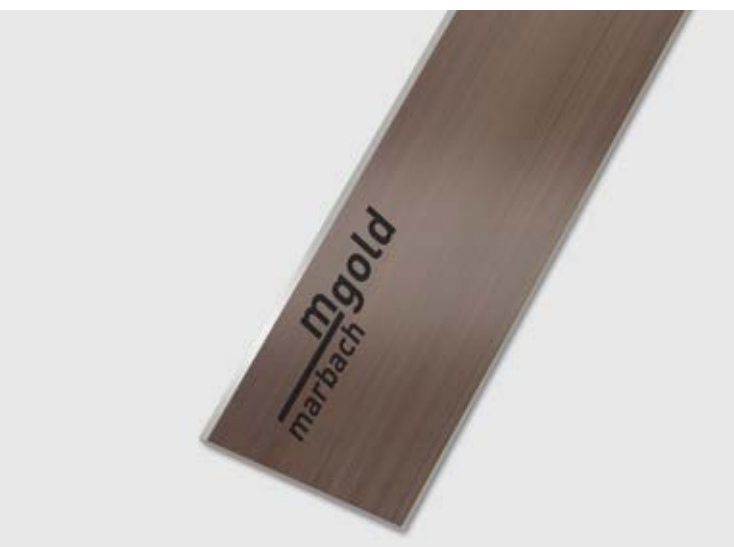

The special cutting rule mgold. Impressive hardness. mgold has a 42° cutting edge. Therefore it is very sharp and works perfectly for cut scores. mgold is optimal for long runs and critical material. Also for cutting metallized cartons and thin metal foils.

| Item no.* | Thickness | Chamfer | PU/Roll |
|-----------|-----------|----------------------|---------|
| 20010 | 2 pt | center bevel; 55 HRC | 100 m |
| 20011 | 2 pt | center bevel; 60 HRC | 100 m |

*item also available by the meter

mpower|s.

THE DURABLE ONE.



mpower|s. For very special requests. mpower|s has the same cutting geometry as mpower. mpower|s is very hard and therefore resistant to abrasive wear and tear. This makes it very durable. Its main use: die-cutting of cosmetic packaging and corrugated board.

| Item no.* | Thickness | Chamfer | PU/Roll |
|-----------|-----------|-------------------|---------|
| 10084 | 2 pt | center bevel | 100 m |
| 10085 | 3 pt | long center bevel | 75 m |

*item also available by the meter

mgold|+.

THE VERY SPECIAL ONE.



Like its little brother mgold, this cutting rule has a 42° edge. Due to this and its special coating, it is not only very sharp but also very hard and therefore suitable for the highest demands. It is extremely resistant to abrasion and is thus used when maximum tool life is required for die-cutting critical materials.

| Item no.* | Thickness | Chamfer | PU/Roll |
|-----------|-----------|----------------------|---------|
| 20020 | 2 pt | center bevel; 60 HRC | 100 m |

*item also available by the meter



mhard|r.

Special rotary cutting rule for processing corrugated board. It protects the counter material and ensures waste-free die cutting. For best productivity. Available in different height and diameter versions.

| Item no. | Name | PU |
|----------|---------------------------------------|--------|
| 08430 | 1.42x25.40 mm curved Ø487 mm; 8 TPI | 30.5 m |
| 08431 | 1.42x25.40 mm straight; 8 TPI | 30.5 m |
| 08535 | 1.42x24.60 mm straight; 8 TPI | 30.5 m |
| 08536 | 1.42x24.60 mm curved Ø487 mm; 8 TPI | 30.5 m |
| 08533 | 1.42x23.80 mm straight; 8 TPI | 30.5 m |
| 08534 | 1.42x23.80 mm curved Ø487 mm; 8 TPI | 30.5 m |

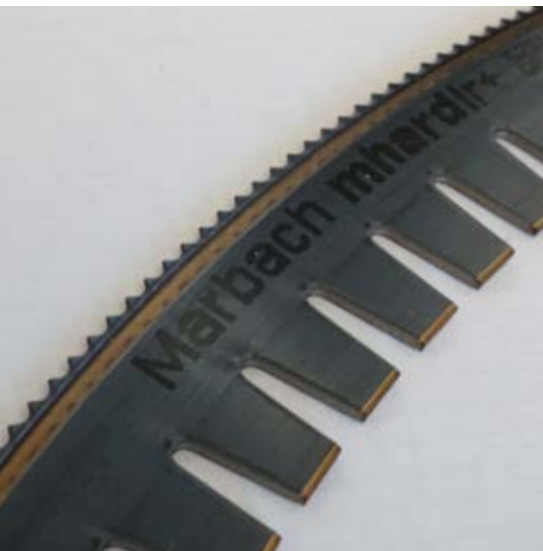

mhard|r+.

New generation of rotary cutting rules. Due to its unique knife hardening and its special corrugated grinding technology, the mhard|r+ cuts the corrugated board very easily. For a smooth die-cutting result – even with high grammages and heavy corrugated board.

| Item no. | Name | PU |
|----------|---------------------------------------|--------|
| 52911 | 1.42x25.40 mm straight; 8 TPI | 30.5 m |
| 52914 | 1.42x25.40 mm curved Ø487 mm; 8 TPI | 30.5 m |
| 52916 | 1.42x25.40 mm curved Ø645 mm; 8 TPI | 30.5 m |
| 52913 | 1.42x26.40 mm straight; 8 TPI | 30.5 m |
| 52917 | 1.42x26.40 mm curved Ø487 mm; 8 TPI | 30.5 m |
| 52912 | 1.42x26.40 mm curved Ø645 mm; 8 TPI | 30.5 m |

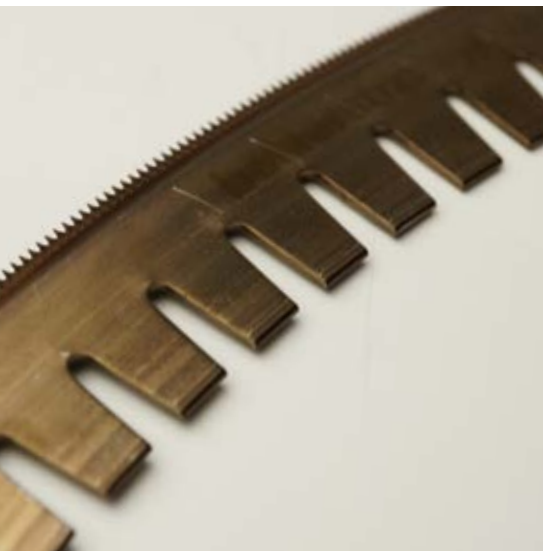

Sawtooth rule.

Rotary cutting rule in special sawtooth version for processing corrugated board. Available in straight and curved versions.

| Item no. | Name | PU |
|----------|-------------------------------------|--------|
| 10682 | 1.42x25.80 mm straight; 20 TPI | 40.0 m |
| 09404 | 1.42x25.80 mm curved Ø487; 20 TPI | 30.5 m |



Perforation rule.

Rotary perforation rule for corrugated paperboard packaging. Ensures exact and easy folding of the blanks. And functional opening mechanisms.

Name

rotation-perforation rule; 1.42x23.8 mm; different gaps/cuts

rotation-perforation rule; 1.42x24.6 mm; different gaps/cuts

rotation-perforation rule; 1.42x25.4 mm; different gaps/cuts

other combinations on request.



Creasing rule.

Standard creasing rule for creasing thin corrugated board. For good creasing results. And functioning folding mechanisms.

| Item no. | Name | PU |
|----------|--------------------------------|--------|
| 08208 | 22.80x1.42 mm curved Ø487 mm | 30.5 m |
| 08269 | 22.10x1.42 mm curved Ø487 mm | 30.5 m |
| 01466 | 23.00x1.42 mm | 45.7 m |
| 01467 | 23.10x1.42 mm | 45.7 m |



Reduced body creasing rule.





Rotary creasing rule in special version for heavy corrugated board types. And double flute. Provides best results with 180° folds.

| Item no. | Name | PU |
|----------|--|--------|
| 08422 | 22.10x3.00x1.42 mm curved Ø487 mm; flat head | 30.5 m |
| 08578 | 23.00x3.00x1.42 mm curved Ø487 mm; flat head | 30.0 m |
| 08669 | 22.60x3.00x1.42 mm straight; flat head | 25.0 m |
| 08468 | 23.00x3.00x1.42 mm straight; flat head | 25.0 m |

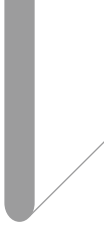
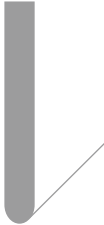
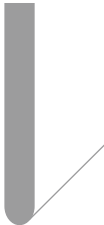
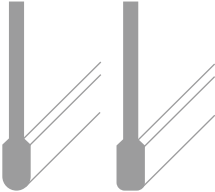

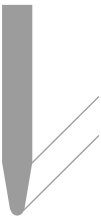
Creasing rules.

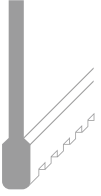
| | Item no. | Thickness | Height | PU |
|---|------------|-----------|--------------------------|-------|
|  <p>2pt (0.71mm)</p> | 01359 | 2pt | 23.20 mm | 20 m |
| | 01360 | 2pt | 23.25 mm | 20 m |
| | 01361 | 2pt | 23.30 mm | 100 m |
| | 01363 | 2pt | 23.40 mm | 100 m |
| | 01365 | 2pt | 23.50 mm | 100 m |
| | 01366 | 2pt | 23.60 mm | 100 m |
| | 01368 | 2pt | 23.80 mm | 20 m |
| | on request | 2pt | 22.00-23.90 mm | 20 m |
|  <p>3pt (1.05mm)</p> | 01425 | 3pt | 22.60 mm | 20 m |
| | 01428 | 3pt | 22.80 mm | 20 m |
| | 01405 | 3pt | 23.00 mm | 20 m |
| | 01407 | 3pt | 23.20 mm | 20 m |
| | 01408 | 3pt | 23.30 mm | 60 m |
| | 01409 | 3pt | 23.40 mm | 50 m |
| | 01410 | 3pt | 23.50 mm | 68 m |
| | 01411M | 3pt | 23.60 mm | 75 m |
| | on request | 3pt | 21.50-23.90 mm | 20 m |
|  <p>4pt (1.42mm)</p> | 01306 | 4pt | 21.70 mm | 20 m |
| | 01314 | 4pt | 22.60 mm | 20 m |
| | 01483 | 4pt | 22.80 mm | 20 m |
| | 01466 | 4pt | 23.00 mm | 20 m |
| | 01468 | 4pt | 23.20 mm | 20 m |
| | on request | 4pt | 21.50-27.00 mm | 20 m |
|  <p>WRT WFT</p> | on request | 3/6pt | 22.20-23.40mm WRT/WFT | 20 m |
| | on request | 3/8pt | 22.20-23.40mm WRT/WFT | 20 m |

| | Item no. | Thickness/ Name | Height x Thickness [mm] | PU |
|---|--|--------------------|-------------------------|-----------------|
|  Crease TT 2pt(0,71mm) | 50268 | TT | 23.60 mm x 2 pt | 20 m |
| | 50267 | TT | 23.70 mm x 2 pt | 20 m |
|  Crease NT 2pt 2/1pt (0,71/0,36 mm) 2/1,5pt (0,71/0,53 mm) | 01544M | NT 2/1pt | 23.00 mm x 2 pt | 20 m |
| | 01545M | NT 2/1pt | 23.10 mm x 2 pt | 20 m |
| | 01546M | NT 2/1pt | 23.20 mm x 2 pt | 20 m |
| | 01548M | NT 2/1pt | 23.30 mm x 2 pt | 20 m |
| | 01562 | NT 2/1pt | 23.85 mm x 2 pt | 20 m |
| | 04165 | NT 2/1,5pt | 23.60 mm x 2 pt | 20 m |
| | 01527 | NT 2/1,5pt | 23.85 mm x 2 pt | 20 m |
|  Headcrease | 08860 | Headcrease | 22.80 mm x 4/8 pt | 20 m |
| | 10472 | Headcrease | 23.00 mm x 4/8 pt | 20 m |
| | 08722 | Headcrease | 22.60 mm x 4/8 pt | 20 m |
| | 50343 | Headcrease | 23.00 mm x 4/8 pt | 20 m |
| | 50312 | Multcrease | 22.80 mm x 4/8 pt | 20 m |
|  Multcrease | 50311 | Multcrease | 23.00 mm x 4/8 pt | 20 m |
| | 50307 | Multcrease | 22.60 mm x 4/8 pt | 20 m |
| | 50308 | Multcrease | 22.80 mm x 4/8 pt | 20 m |
| | 50315 | Multcrease | 23.00 mm x 4/8 pt | 20 m |
| |  Wave crease | 01168 | Wave crease | 22.40 mm x 3 pt |
| 01166 | | Wave crease | 22.60 mm x 3 pt | 20 m |
| 01165 | | Wave crease | 22.80 mm x 3 pt | 20 m |
| 01164 | | Wave crease | 23.00 mm x 3 pt | 20 m |
| 01163 | | Wave crease | 23.20 mm x 3 pt | 20 m |



Crease-cut combination rules. PERFORATION RULES.

Perforation rules are available in different versions. In the thicknesses 2 pt, 3 pt or 4 pt. All rules are available by the meter. For completely individual perforations.

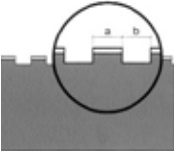
| Perforation | Thickness | PU |
|--|-----------|------|
|  | 2 pt | 20 m |
| | 3 pt | 20 m |
| | 4 pt | 20 m |

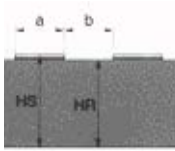
| Combo-perforation | Thickness | PU |
|---|-----------|------|
|  | 2 pt | 20 m |
| | 3 pt | 20 m |
| | 4 pt | 20 m |



Tear perforation rules.

Tear perforation rules are available in different versions. Left or right. In thicknesses of 2pt or 3pt. For tear open mechanisms that work. All rules are available by the meter.

Fishbone rule

| Item no. | Thickness | Height | PU |
|----------|-----------|----------|------|
| 10549M | 2pt 3pt | 23.80 mm | 20 m |
| 10548M | 2pt 3pt | 23.80 mm | 20 m |
| 10547M | 2pt 3pt | 23.80 mm | 20 m |
| 10540M | 2pt | 23.80 mm | 20 m |

further tear perforation rules on request

Sharklinie

| Item no. | Thickness | Height | PU |
|----------|-----------|----------|------|
| 01446M | 2pt | 23.80 mm | 20 m |
| 01433M | 3pt | 23.80 mm | 20 m |
| 01892M | 3pt | 23.80 mm | 20 m |
| 01435M | 3pt | 23.80 mm | 20 m |

further tear perforation rules on request

Wave rule.

Special rule with wavy edge. This is used when the packaging should be equipped with safe cutting edges. For increased safety when finished products are assembled.

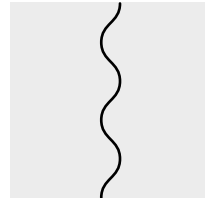
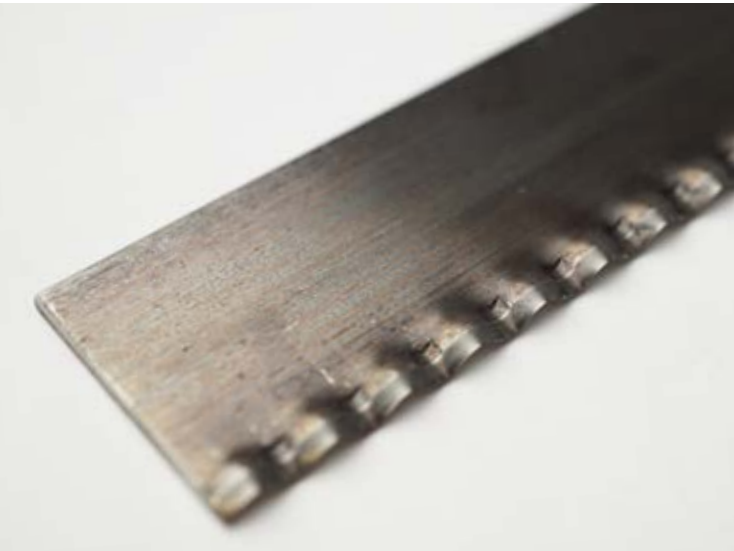

| Item no. | Type | Thickness | Height | PU |
|----------|--------|-----------|----------|------|
| 01102 | 2.0 mm | 3pt | 23.80 mm | 20 m |
| 01102M | 2.0 mm | 3pt | 23.80 mm | 20 m |
| 01101 | 3.5 mm | 3pt | 23.80 mm | 20 m |
| 01101M | 3.5 mm | 3pt | 23.80 mm | 20 m |
| 01162 | 5.0 mm | 3pt | 23.80 mm | 20 m |
| 01162M | 5.0 mm | 3pt | 23.80 mm | 20 m |

Deckle edge rule.

Special rule with edge for stamped outer contour. When cut with a deckle edge rule the produced packaging gets an attractive look and convinces with it's aesthetic look.

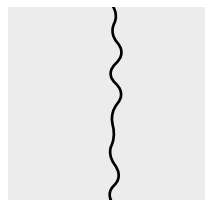
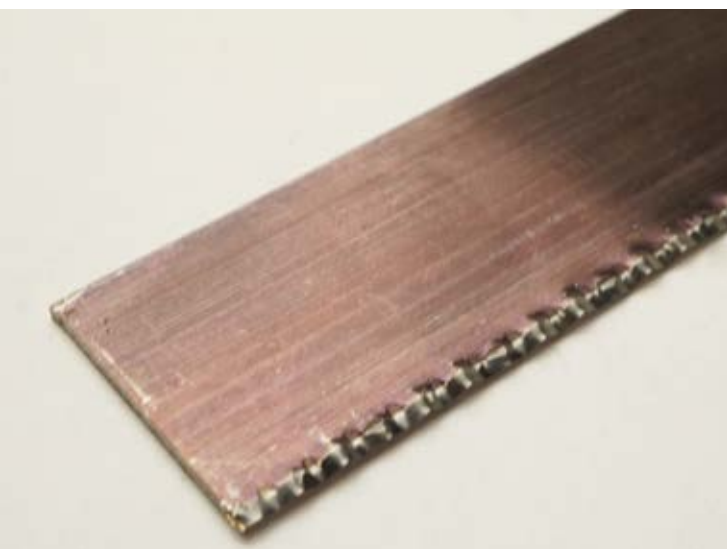

| Item no. | Name | PU |
|----------|---------------|------|
| 01832M | 1.05x23.80 mm | 20 m |
| 01934M | 1.05x23.80 mm | 20 m |

Special geometric rule.



Further development of the wave rule for flat tools. Optimized cutting edge protection for users. Resulting in highest safety when assembling finished products. The cutting result is similar to a rotary cut packaging with mhard|r.

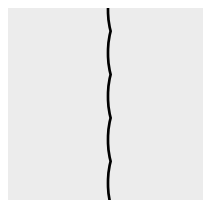

| Item no. | Name | PU |
|----------|---------------|------|
| 01121 | 1.05x23.80 mm | 20 m |

Special rule.



A special cutting knife for optimal reverse cutting of the paperboard material. Highly precise and very sharp. For tear mechanisms that not only work perfectly, but are also visually attractive.

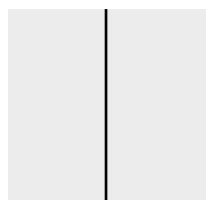

| Item no. | Name | PU |
|----------|--|------------|
| 01995M | reverse cutting plate 12x 1,000 mm/ 0.8 mm/ 0.3 mm Angle 70° | ab 10 m |
| 01997M | reverse cutting plate-perforations | on request |

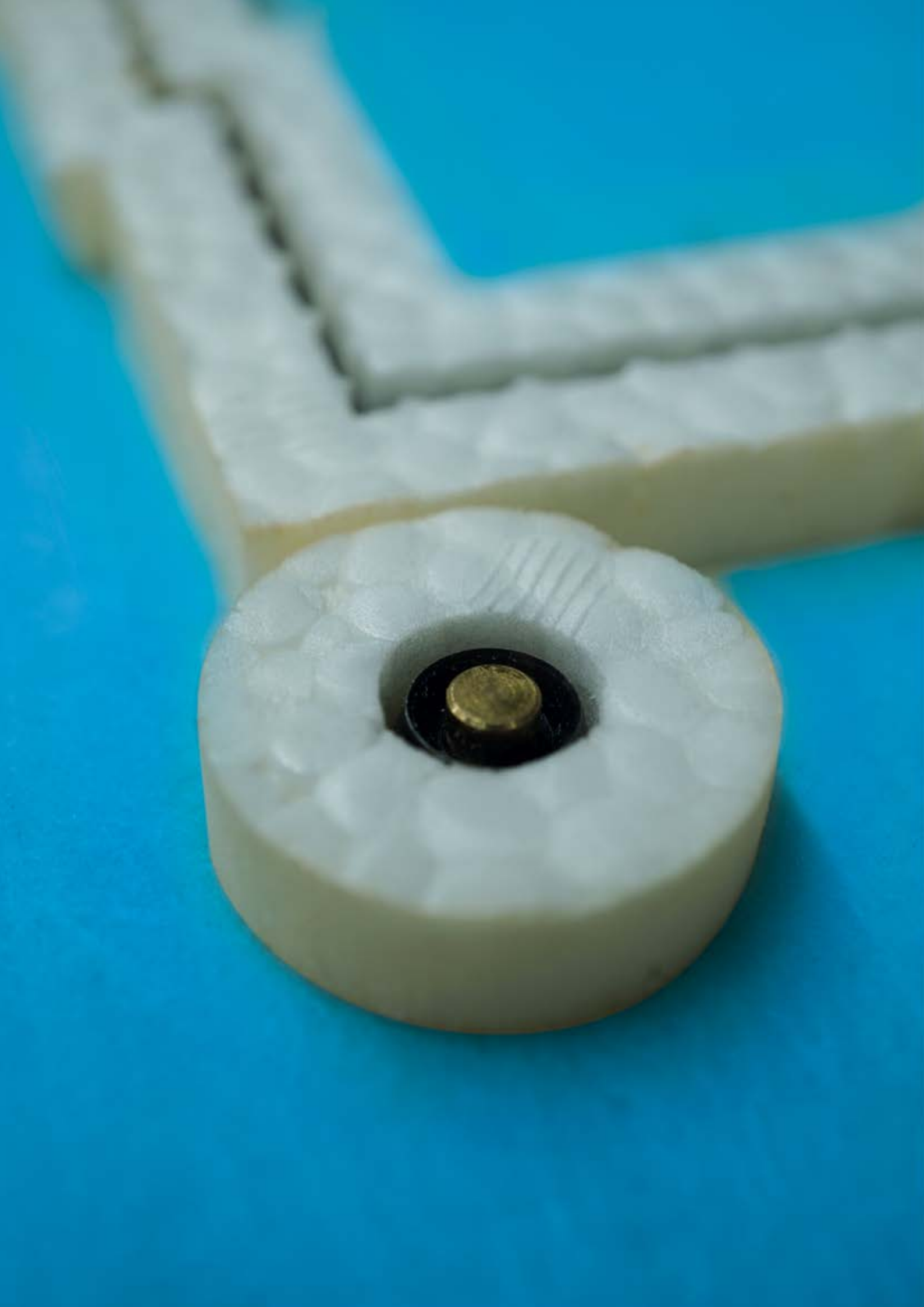



HOLE PUNCHES. BENT CUTTING CIRCLES.

To cut perfect round circles, there are several options: Bent cutting circles or hole punches. For small diameters up to 10 mm, ready-made hole punches are the perfect solution. For diameters of 11 mm and more, we recommend bent mpower cutting circles made of hardened steel. With brass ejector and adjustable pressure spring.

| Bent cutting circles | Item no. | Ø | Height |
|----------------------|----------|----|----------|
| | 02069 | 11 | 23.80 mm |
| | 02022 | 12 | 23.80 mm |
| | 02024 | 13 | 23.80 mm |
| | 02026 | 14 | 23.80 mm |
| | 02028 | 15 | 23.80 mm |
| | 02030 | 16 | 23.80 mm |
| | 02032 | 17 | 23.80 mm |
| | 02870 | 18 | 23.80 mm |
| | 02871 | 19 | 23.80 mm |
| | 02865 | 20 | 23.80 mm |
| | 02864 | 21 | 23.80 mm |
| | 02863 | 22 | 23.80 mm |
| | 02872 | 23 | 23.80 mm |
| | 02862 | 24 | 23.80 mm |
| | 02860 | 25 | 23.80 mm |
| | 02866 | 26 | 23.80 mm |
| | 02873 | 27 | 23.80 mm |
| | 02867 | 28 | 23.80 mm |
| | 02861 | 30 | 23.80 mm |
| | 02875 | 31 | 23.80 mm |
| | 02868 | 32 | 23.80 mm |
| | 02874 | 34 | 23.80 mm |
| | 02869 | 35 | 23.80 mm |



Finished parts
mpower

| Hole punches Types | Item no. | Ø | Height |
|--------------------|----------|----|----------|
| | 02172 | 3 | 23.80 mm |
| | 01145 | 4 | 23.80 mm |
| | 01147 | 5 | 23.80 mm |
| | 01149 | 6 | 23.80 mm |
| | 01173 | 7 | 23.80 mm |
| | 01177 | 8 | 23.80 mm |
| | 01179 | 9 | 23.80 mm |
| | 01183 | 10 | 23.80 mm |
| | 02799 | 1 | 23.80 mm |
| | 02801 | 2 | 23.80 mm |
| | 02803 | 3 | 23.80 mm |
| | 02805 | 4 | 23.80 mm |
| | 02807 | 5 | 23.80 mm |
| | 02809 | 6 | 23.80 mm |
| | 02811 | 7 | 23.80 mm |
| | 02813 | 8 | 23.80 mm |
| | 02815 | 9 | 23.80 mm |
| | 02817 | 10 | 23.80 mm |

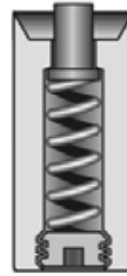

FB*

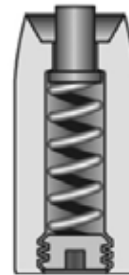

G**

*on request available up to Ø 23 mm

**on request available up to Ø 20 mm



CORRUGATED BOARD RUBBERING.

FORM PARTS FOR FLAT DIE-CUTTING.

Flat die-cutting of corrugated board requires a rubbering perfectly matched to the material. Our extensive rubber range ensures productivity in the production of your packaging. As sheet material, profiles or form parts.







Form parts

| Item no. | Name | Dimensions | Hardness | Color |
|-------------|----------------------|--------------|----------|--------|
| 15819CF-10 | cellrubber softpower | 10x10x500 mm | 20 shore | black |
| 15819CF-10A | cellrubber softpower | 10x10x500 mm | 20 shore | black |
| 03345CF-13 | cellrubber softpower | 13x13x500 mm | 20 shore | black |
| 03345CF-13A | cellrubber softpower | 13x13x500 mm | 20 shore | black |
| 05089CF-10 | flexpower s soft | 10x10x500 mm | 20 shore | white |
| 05089CF-10A | flexpower s soft | 10x10x500 mm | 20 shore | white |
| 05094CF-13 | flexpower s soft | 13x13x500 mm | 20 shore | white |
| 05094CF-13A | flexpower s soft | 13x13x500 mm | 20 shore | white |
| 05097CF-10 | flexpower h hard | 10x10x500 mm | 40 shore | white |
| 05098CF-13 | flexpower h hard | 13x13x500 mm | 40 shore | white |
| 20013CF-10 | elastomer PUR | 10x10x658 mm | 20 shore | yellow |
| 20005CF-14 | elastomer PUR | 14x14x658 mm | 20 shore | yellow |

CORRUGATED BOARD RUBBERING.

PROFILES FOR FLAT DIE-CUTTING.

Profiles

| Item no. | Name | Dimensions | Hardness | Color | Profile |
|----------|--------------------------------------|-------------------|----------|--------|---|
| 03514 | G 2.1 - A1 | 10x10x1,000 mm | 60 shore | black |  |
| 03518 | G 2.12 - C3 | 7x12.5x1,000 mm | 60 shore | black |  |
| 03501 | C3-0 | 7.5x12.5x1,000 mm | 65 shore | red |  |
| 09399 | profile rubber hard | 9.1/7.0x5x500 mm | 75 shore | white |  |
| 09398 | profile rubber hard | 8.5/7.5x5x600 mm | 75 shore | white | |
| 09397 | profile rubber hard | 11/9x5x500 mm | 75 shore | white | |
| 03512 | profile rubber easy crease | 8x15x600 mm | 20 shore | black |  |
| 08162 | profile rubber easy crease | 9x15x590 mm | 55 shore | black | |
| 08161 | profile rubber easy crease | 11x15x600 mm | 55 shore | black | |
| 50185 | C 14 Soft | 14x12.5x1,000 mm | 25 shore | red |  |
| 50185 | G 2.5 - C11 soft red | 11x12.5x1,000 mm | 25 shore | red | |
| 08670 | C 9.5 | 9.5x10.5x600 mm | 60 shore | black |  |
| 10969 | profile Vulkollan [®] | 14x14x530 mm | 40 shore | yellow | |
| 03450 | profile Vulkollan [®] | 10x10x480 mm | 40 shore | yellow | |
| 03542 | wedge profile Vulkollan [®] | 12x16x500 mm | 40 shore | yellow |  |
| 03543 | wedge profile Vulkollan [®] | 14x16x500 mm | 40 shore | yellow | |
| 09241 | clean-cut rubber | 9x12 mm | 55 shore | black |  |
| 09240 | clamping strip for clean-cut rubber | 17x4.4x1,000 mm | | clear | |



CORRUGATED BOARD RUBBERING.

FORM PARTS FOR ROTARY DIE-CUTTING.

When rotary die cutting corrugated board, the ejector function is particularly important. We know exactly which rubber should be used at which place. And have an extensive range of rubber materials. The choice is yours.



Form parts

| Item no. | Name | Dimensions | Hardness | Color |
|-------------|----------------------|----------------|----------|-------|
| 15821C-1230 | cellrubber softpower | 12x12x30 mm | 20 shore | black |
| 15821C-1240 | cellrubber softpower | 12x12x40 mm | 20 shore | black |
| 15822C-1430 | cellrubber softpower | 14x14x30 mm | 20 shore | black |
| 15822C-1440 | cellrubber softpower | 14x14x40 mm | 20 shore | black |
| 15822CF-14 | cellrubber softpower | 14x14x500 mm | 20 shore | black |
| 15822CF-14A | cellrubber softpower | 14x14x500 mm | 20 shore | black |
| 05095C-1230 | flexpower s soft | 12x12x30 mm | 20 shore | white |
| 05095C-1240 | flexpower s soft | 12x12x40 mm | 20 shore | white |
| 05096C-1430 | flexpower s soft | 14x14x30 mm | 20 shore | white |
| 05096C-1440 | flexpower s soft | 14x14x40 mm | 20 shore | white |
| 05109CF-25A | flexpower s soft | 7x25x1,000 mm | 20 shore | white |
| 05089CF-25 | flexpower s soft | 10x25x1,000 mm | 20 shore | white |
| 05095CF-12 | flexpower s soft | 12x12x500 mm | 20 shore | white |
| 05096C-14 | flexpower s soft | 14x14x500 mm | 20 shore | white |
| 05038C-1630 | flexpower s soft | 16x16x30 mm | 20 shore | white |
| 05126C-0730 | flexpower h hard | 7x7x30 mm | 40 shore | white |
| 05107CF-16 | flexpower h hard | 16x16x500 mm | 40 shore | white |



CORRUGATED BOARD RUBBERING. PROFILES FOR ROTARY DIE-CUTTING.

Profiles

| Item no. | Name | Dimensions | Hardness | Color | Profile |
|----------|---|--------------|----------|--------|---|
| 09775M | cell Vulkollan [®] profil RG 50 | 10x12x500 mm | 35 shore | yellow |  |
| 10940 | crease profile rubber | 6.35x20 mm | 70 shore | black | |
| 10941 | crease profile rubber | 6.99x20 mm | 70 shore | black | |
| 10942 | crease profile rubber | 7.50x20 mm | 70 shore | black | |
| 10943 | crease profile rubber | 8.50x20 mm | 70 shore | black |  |
| 10945 | crease profile rubber | 9.65x20 mm | 70 shore | black | |
| 10947 | crease profile rubber | 9.40x20 mm | 70 shore | black | |
| 10948 | crease profile rubber | 8.00x20 mm | 70 shore | black | |
| 10969 | profile Vulkollan [®] | 14x14x530 mm | 40 shore | black |  |

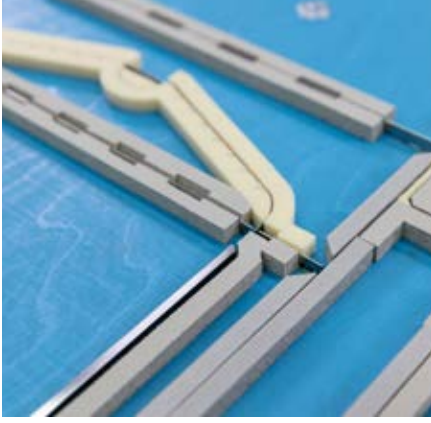





RUBBERING PAPERBOARD. FORM PARTS & PROFILES FOR FLAT DIE-CUTTING.

When die-cutting paperboard, the rubbering plays an important role in the die-cutting process. Different cartonboard materials require different rubbering. For optimum functionality, the rubbering must be individually adapted to the requirements of the job. The rubbering materials used by Marbach are diverse. And all from carefully selected suppliers. Many even produced exclusively for us. This ensures a long service life and best functionality.

Form parts

| Item no. | Name | Dimensions | Hardness | Color |
|------------|------------------|------------|----------|--------|
| 03044CF-07 | moose rubber | 7x7x500 mm | 35 shore | grey |
| 03007CF-07 | Vulkollan® | 7x7x500 mm | 40 shore | yellow |
| 03014CF-07 | Vulkollan® | 7x7x500 mm | 55 shore | yellow |
| 03074CF-07 | cellrubber | 7x7x500 mm | 15 shore | black |
| 05126CF-02 | flexpower h hard | 7x7x500 mm | 40 shore | black |

Profiles

| Item no. | Name | Dimensions | Hardness | Color | Profile |
|----------|-------------------------------------|----------------|----------|-------|---|
| 03431 | profile cork | 7x7x630 mm | 65 shore | brown |  |
| 03429 | profile rubber NRB | 7.3x8x1,000 mm | 70 shore | white |  |
| 03420 | profile cork; R4,5 strongly rounded | 7x7.3x640 mm | 65 shore | brown |  |
| 03421 | profile cork ; T-profile rounded | 7x5x640 mm | 65 shore | brown |  |

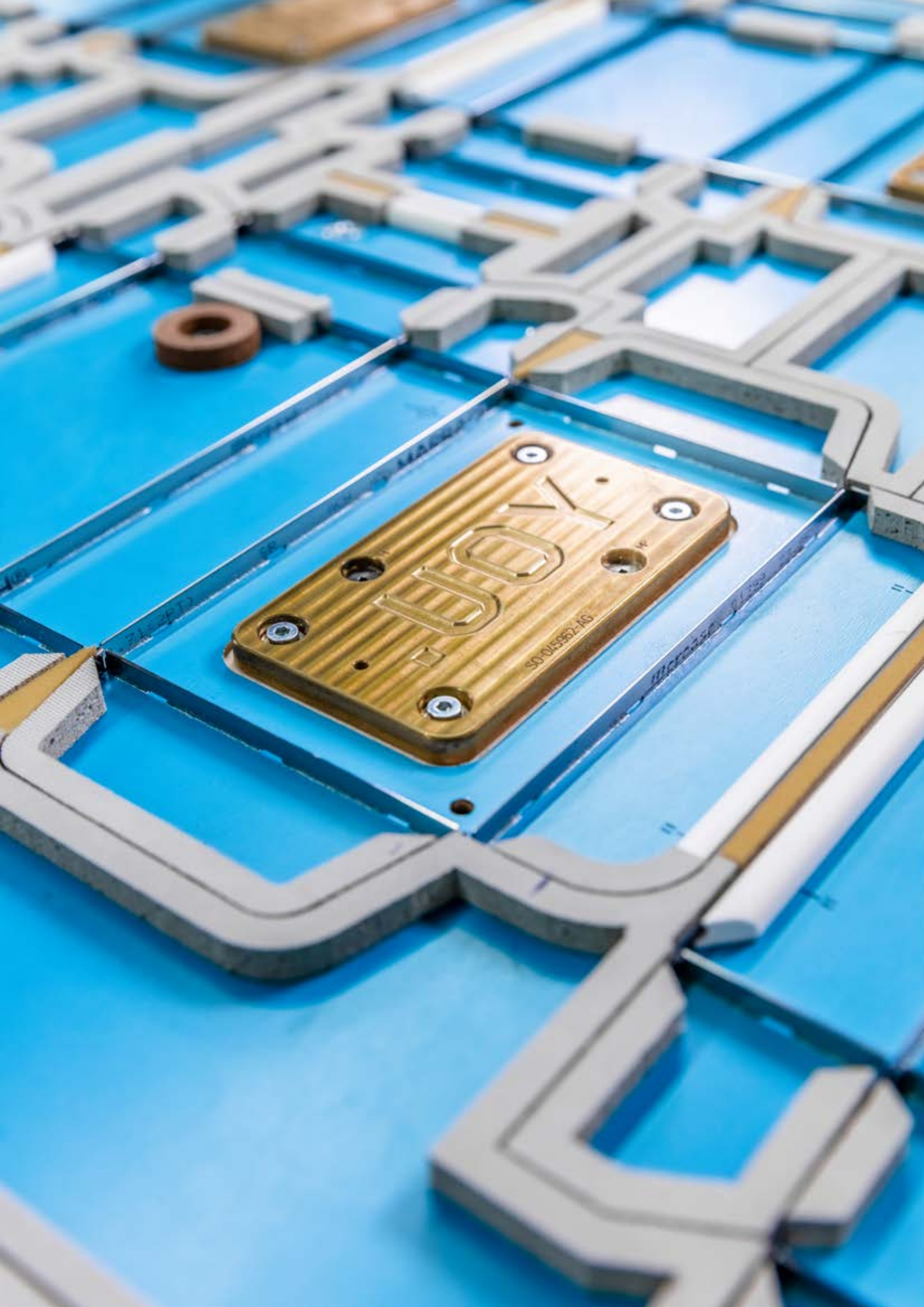

EMBOSSING.



Shim foils

Pressure-resistant foils in defined thicknesses. For accurate and fast make-ready.

PU = 50 m roll

| Item no. | Name |
|----------|--------------|
| 00670 | 0.05x600 mm |
| 00673 | 0.10 x610 mm |
| 00671 | 0.20x600 mm |



Torx screwdriver

Screwdriver for embossings and crease plates. Torx version. For best power transmission.

| Item no. | Name |
|----------|--------|
| 44212 | Tx8 |
| 44211 | Tx20 |
| 44215 | Tx8x60 |



Memo pin system

Special pins for archiving the embossing position in the blank.

PU = 100 pcs.

| Item no. | Name |
|----------|----------------------------------|
| 14065 | M4x12 allen |
| 14080 | disc for M4 |
| 14059 | M3x12 allen |
| 14081 | disc for M3 |
| 13040 | M4x8 torx for 3 mm female plate |
| 13041 | M4x8 allen for 3 mm female plate |
| 15005 | memopin |



CREASE PLATES



Flat screw sockets

Screw sockets for flat head screws. For secure fastening of crease plates. And easy positioning. In different versions.

| Item no. | Name |
|----------|--------------------|
| 13082 | 11.5/17.5/Ø 8.0 mm |
| 13089 | 11.5/17.5/Ø 8.5 mm |



Flat screws and washers

Special screws for the assembly of crease plates. Torx version. Suitable for flat screw sockets item no. 13082 and 13089.

| Item no. | Name |
|----------|-----------------|
| 13040 | M4x8 Torx |
| 13041 | M4x8 hexagonal |
| 14085 | disc 4x8x0.5 mm |
| 44212 | screwdriver Tx8 |



Fitting pins and sockets

For crease plates with flat sockets and embossing register system.

| Item no. | Name |
|----------|--------------------------------|
| 14369 | Marbach 5 mm pins Ø 5x50 mm |
| 55794 | crease plate fixation |
| 14176 | drill socket, length 12 mm |



Countersunk screw sockets

Special countersunk screw sockets. Without pins. User-friendly and space-saving. No additional cutout in the crease plate necessary. For narrow places. And fast and easy positioning of the creasing plate.

| Item no. | Name |
|----------|------------------|
| 55797 | 11.5/20/Ø 8.0 mm |



Countersunk screws

Special countersunk screws for screwing crease plates. Torx version. With extremely flat head. Suitable for countersunk screw sockets item no. 55797.

| Item no. | Name |
|----------|------------------|
| 42801 | M4x10 Tx20 |
| 44211 | screwdriver Tx20 |



Brass sockets for crease plates

Sockets for mounting brass thread inserts of embossings into the crease plate. In two versions: M3 and M4.

| Item no. | Name |
|----------|-------------------|
| 14325 | thread inserts M3 |
| 14326 | thread inserts M4 |

BRAILLE.



Braille females

Standard marbabraille females in different versions. As a counterpart to marbasteel male embossings. For optimal shaping of braille dots. And an optimal braille result.

on request

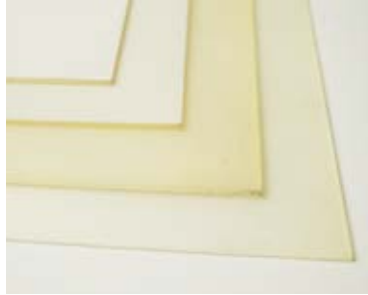

Elastomer segments

Elastic base as raw material. To be cut to size. For elastic embossing.

| Item no. | Dimensions |
|----------|-----------------|
| 09789 | 480x250x1.45 mm |
| 09790 | 480x250x1.40 mm |
| 09791 | 160x300x1.05 mm |
| 09792 | 160x300x1.55 mm |



Screws and pins

Fixing elements for marbabraille females on the cutting die.

PU = 100 pcs.

| Item no. | Name |
|----------|-------------------------------|
| 14236 | lens head screw M 3x5 |
| 06607 | rectangular bolt 5x5x19.50 mm |



Shim foils

Pressure-resistant foils in defined thicknesses. For accurate and fast make-ready.

PU = 50 m roll

| Item no. | Name |
|----------|--------------|
| 00670 | 0.05x600 mm |
| 00673 | 0.10 x610 mm |
| 00671 | 0.20x600 mm |



Adhesive foils

Double-sided adhesive film for lamination. For various purposes of application.

| Item no. | Name |
|----------|--------------------------------|
| 44011 | 0.10 mmx25 m |
| 44101 | 0.13 mmx50 m |
| 44012 | 0.20 mmx10 m |
| 44103 | 0.25 mmx10 m |
| 00586 | magnetic foil 0.65x615 mmx30 m |



Digimes

Digital measuring device for determining the height of braille dots on the male die and on the paperboard. Fast and safe. According to DIN EN 15823.

- Measuring range: 0-10 mm
- Resolution: 0.01 mm
- Switching inch/mm

| Item no. | Name |
|----------|---------|
| G-1750 | Digimes |



STEEL AND WOODEN RAILS.

Wooden rails multiplex natural, lower part stabilization

| Item no. | Name | Application | Version | PU |
|----------|-------|--------------------------------------|---------------|---------|
| L-HLZ25 | 25 mm | paperboard processing machines | 15 mm 18 mm | 50 pcs. |
| L-HLZ35 | 35 mm | paperboard processing machines | 15 mm 18 mm | 50 pcs. |
| L-HLZ50 | 50 mm | corrugated board processing machines | 12 mm 15 mm | 50 pcs. |

Steel rails, lower part stabilization

| Item no. | Name | Application | Version | PU |
|----------|-------|--------------------------------------|--------------------|---------|
| L-STL25 | 25 mm | paperboard processing machines | 4 mm 6 mm | 50 pcs. |
| L-STL35 | 35 mm | paperboard processing machines | 4 mm 6 mm | 50 pcs. |
| L-STL50 | 50 mm | corrugated board processing machines | 2 mm 3 mm 4 mm | 50 pcs. |

Fixing elements for steel rails

| Item no. | Name | Application | Version | PU |
|----------|----------------------|--------------------------------|----------|------------|
| 07481 | mounting angle steel | rail fixation wood and steel | | 500 pcs. |
| 13280 | flat head screw | mounting steel rails (angle) | M6x12 mm | 100 pcs. |
| 00738 | flat head screw | mounting wooden rails claw | | 100 pcs. |
| 04986 | drive-in nut | assembly lower part with angle | M5x8 mm | 1,000 pcs. |
| 13284 | flat head screw | assembly lower part with angle | M5x10 mm | 100 pcs. |
| 14284 | claw plastic | assembly with rails | 25 mm | 100 pcs. |

Cross stabilization SPO

| Item no. | Name | Application | Version | PU |
|----------|--------------------------|-----------------------------------|----------|----------|
| 07483 | stabilization tube | assembly with wooden rails | 2,000 mm | 25 pcs. |
| 09158 | clamping block standard | assembly pipe with female tool | | 100 pcs. |
| 09157 | clamping block end piece | assembly of pipe with female tool | | 100 pcs. |
| 14163 | lens head screw | assembly of clamping blocks | M5x30 mm | 100 pcs. |

STRIPPING.



Speed-Lift and Speed-Lift-S

Sheet lifter for stripping tools. Retrofittable. In 2 sizes. The Speed-Lift Precision drill drills the appropriate cut-outs.

*PU = 500 pcs.

| Item no. | Name |
|----------|------------------------------|
| 13045 | Speed-Lift |
| 13046 | Speed-Lift Precision drill |
| 13091 | Speed-Lift-S |
| 13092 | Speed-Lift-S Precision drill |



Easy-Fix and Easy-Fix-S

Transport locks for tools. One-piece, making them fast and safe to handle. Available in the two versions Easy Fix (male and female stripper) and Easy Fix S (guillotine with tool).

PU = 1,000 pcs.

| Item no. | Name |
|----------|------------------|
| 07450 | Easy-Fix blue* |
| 06900 | Easy-Fix-S blue* |

*only as long as stock lasts



Clamp

With Mastercut machines. Connects both guillotines. Ensures a safe transport and space saving storage.

PU = 100 pcs.

| Item no. | Name |
|----------|-------|
| 19000 | Clamp |



Precision lower pin

Special precision lower pins for stable stripping processes in packaging production. It is manufactured extremely precisely from high-quality materials and is very accurate in position due to its narrow guide tolerances. Re-adjustment in the die-cutting machine is not necessary. For trouble-free and waste-free stripping processes.

PU = 50 pcs.

| Item no. | Name |
|----------|-------------------------|
| 00278 | standard (4 mm) |
| 00277 | reduced diameter (2 mm) |



Bottom pin

The standard bottom pin for stripping: 4 mm. And for the smallest waste parts, a special bottom pin. Turned down to 2 mm. So that even the smallest waste parts can be stripped safely and stably.

PU = 50 pcs.

| Item no. | Name |
|----------|-------------------------|
| 10841 | reduced diameter (2 mm) |
| 10840 | standard (4 mm) |



marbapoint

The precision set-up helper for a highly efficient stripping process. So set-up of the stripper in the cutting machine is easy as pie.

| Item no. | Name |
|----------|--------------------------|
| 09966 | marbapoint set |
| 09984 | marbapoint |
| 09985 | replacement battery |
| 15048 | recording socket |
| 09971 | magnet holder marbapoint |



Stripping claws

Unique. For dynamic stripping. The waste is held in place with the claw tips. And pressed through the lower tool. The special support technology in the lower tool ensures a controlled stripping of the waste. Available in various sizes. Left and right.

PU = 500 pcs.

| Item no. | Name |
|----------|-------------|
| 09502 | 4 mm left |
| 09503 | 4 mm right |
| 09504 | 6 mm left |
| 09507 | 6 mm right |
| 09508 | 8 mm left |
| 09509 | 8 mm right |
| 09501 | 10 mm left |
| 09511 | 10 mm right |
| 09512 | 12 mm left |
| 09513 | 12 mm right |
| 09515 | 15 mm left |
| 09516 | 15 mm right |
| 09520 | 20 mm left |
| 09521 | 20 mm right |

further claw types on request



marbafly

PU = 100 pcs.

| Item no. | Name |
|----------|------------|
| 08968 | marbafly c |
| 09232 | marbafly s |



Crown pins

They firmly fix the waste pcs.. And are used in places where a claw does not fit. Especially useful for tiny waste pieces. And small side waste. Available in various sizes.

PU = 1,000 pcs.

| Item no. | Name |
|----------|--------|
| 42421 | 1.8 mm |
| 42422 | 3.0 mm |
| 42423 | 5.0 mm |



Foam cubes

For stable stripping: foam cubes as down holders. Self-adhesive. In various sizes. Just peel them off. Put in place. Done.

PU = 1 box

| Item no. | Name |
|----------|------------------------------|
| 03248 | 30x40x40 mm (4,752 pcs./box) |
| 03247 | 40x40x40 mm (3,600 pcs./box) |
| 03246 | 75x40x40 mm (1,872 pcs./box) |



Assembly aid

Simple. But effective. Special assembly aid for the assembly of crown pins. Or marbastrip claws.

PU = 1,000 pcs.

| Item no. | Name |
|----------|---------|
| 10456 | Ø1.8 mm |
| 10455 | Ø2.2 mm |
| 10458 | Ø3.0 mm |
| 10457 | Ø5.0 mm |
| 09708 | claws |



Spring elements

Special telescope spring elements for Marbach stripping tools masterstrip|plate. In 2 versions.

| Item no. | Name |
|----------|----------|
| 07703 | threaded |
| 07706 | pin |

BLANKING.



Jogger tape

Jogger tapes for guiding the blanks during the blanking process. With steel insert. They ensure safe stacking of the blanks.

| Item no. | Dimensions |
|----------|-----------------------------------|
| 14157 | 19.0 mm; 16.5 m |
| 44030 | 25.4 mm; 16.5 m |
| 07550 | steel insert 12.7x0.10 mm; 5 m |



Center block

Center block for insertion into the blanking tool. Ensures fast and accurate positioning of the tool in the die-cutting machine. For fast set-up times.

| Item no. | Name |
|----------|--------------|
| 07427 | center block |

further versions on request

PU = 100 pcs.



Distance element

Distance element for stripping and blanking tools. Provides best stability due to its extra large contact surface.

| Item no. | Name |
|----------|----------------|
| 14425 | bolt (30 mm) |
| 50203 | sleeve (30 mm) |

PU = 100 pcs.

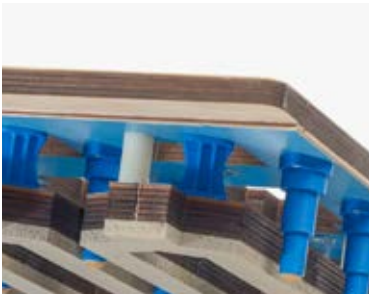

Wood and rubber

Building tools like professionals. With original materials from Marbach. For blanking: 18 mm wood and 7 mm moose rubber. Well equipped for an efficient blanking process.

| Item no. | Dimensions |
|----------|------------------------------|
| 00934 | multiplex 1,500x1,120 mm |
| 03044 | moose rubber 1,000x500 mm |



lightblanker frame

Our universal frame. Stays in the machine. Available in various sizes. Fitting for all common machines with blanking station.

| Item no. | Machine |
|----------|---------|
| M-7410 | 76-106 |
| M-7410 | 130-145 |





Jiggers

For optimum guidance of the separated blanks in the edge area. Lightweight, stable and inexpensive. Available in various lengths. Individually adaptable.

PU = 100 pcs.

Item no. Name

| | |
|-------|---------------|
| 09997 | standard |
| 09983 | version long |
| 09927 | version small |



marbapusher|p

This presser is an allrounder. It can be used for both presser plates and custom-shaped presser bars. And it saves storage space as it doesn't stand out on the back of the tool.

PU = 100 pcs.

Item no. Name

| | |
|-------|---------------|
| 34134 | marbapusher p |
|-------|---------------|



marbapusher|s

The Marbach telescopic presser. Lightweight, conomical and space-saving. Flush to the back of the tool. Fits even where there is little room.

PU = 100 pcs.

Item no. Name

| | |
|-------|---------------|
| 34147 | marbapusher s |
|-------|---------------|



marbapusher-set

Pressers designed by Marbach. Lightweight, versatile and economical. Quick and safe assembly in seconds. Set of 25 pcs. with fitting keys. Without screws.

Item no. Name

| | |
|-------|-----------------|
| 34159 | marbapusher-set |
|-------|-----------------|



marbapusher

Pusher developed by Marbach for the selective fixation of waste areas. Lightweight, flexible to use and inexpensive. Quickly mounted and easy to handle.

PU = 100 pcs.

Item no. Name

| | |
|-------|-------------|
| 34158 | marbapusher |
|-------|-------------|



Pressers

Conventional pressers for male blankers. Usable with a bar. As a spot presser or in a presser plate. Stable, reliable and popular.

Item no. Name

| | |
|-------|-------------------|
| 34148 | spot presser |
| 34149 | for presser plate |
| 34150 | for presser bar |

MDSS. PERFECTLY STORED.

Good in-house logistics saves you time. Store your cutting dies in the Marbach die storage system (MDSS). The MDSS is available for flat and for rotary cutting dies.

In the MDSS the dies are stored safely, can be found quickly and are accessible at any time. Due to its modular design, it can be configured according to your individual requirements. Depending on the MDSS version, various handling systems are available to transport the dies quickly and safely to their place of use.

| Item no. | Name |
|----------|--|
| G-6000 | modular system, price depends on number and size of cassettes or shell diameters |





CREASE BEND TESTER. MEASURING PAPERBOARD SAMPLES.

The packaging has to fit. To the product and to the filling process. For optimum packaging quality, you need a suitable control system. A system with which you can reliably measure the crease values and the folding resistance of a package. A system that makes no mistakes. A system that ensures maximum machine speeds and a smooth packaging process for your customers.

The crease bend tester is a quality assurance system for your entire packaging process: from the initial tests in the laboratory to continuous tests during packaging production. All the way to the final inspection before the packaging is delivered to your customer. But that's not all. The crease bend tester is also the device of choice for optimizing repeat orders and checking incoming material deliveries.

| Item no. | Name |
|----------|--------------------|
| G-4100 | crease bend tester |



SAMPLE CUTTER.

CUT AND CREASE PAPERBOARD SAMPLES.

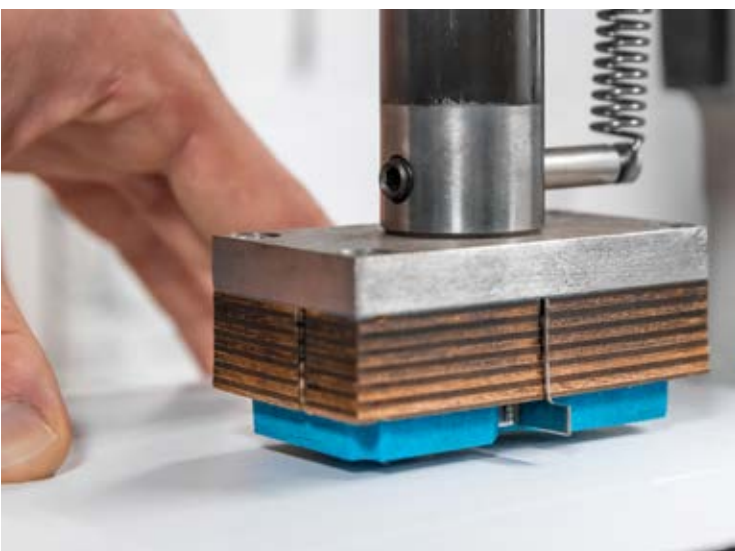

For an easy production of test samples for the crease bend tester it is recommended to use the sample cutter. With this, samples with the size 60 mmx25 mm can be cut. The sample cutter and suitable tools are equipped with a visual aid. This ensures the correct position for cutting the paperboard strips quickly and precisely.

| Item no. | Name |
|----------|---------------|
| G-4010 | sample cutter |

HYDRAULIC PRESS.

CREATE CREASED SAMPLES.



The hydraulic press allows you to easily create a number of creased samples with different specifications of creasing rules and creasing channels. After creasing, the visual control of the samples itself gives useful information about the characteristics of the material. The hydraulic unit of the press can create a pressure of up to 60 kN.

| Item no. | Name |
|----------|-----------------|
| G-4040 | hydraulic press |

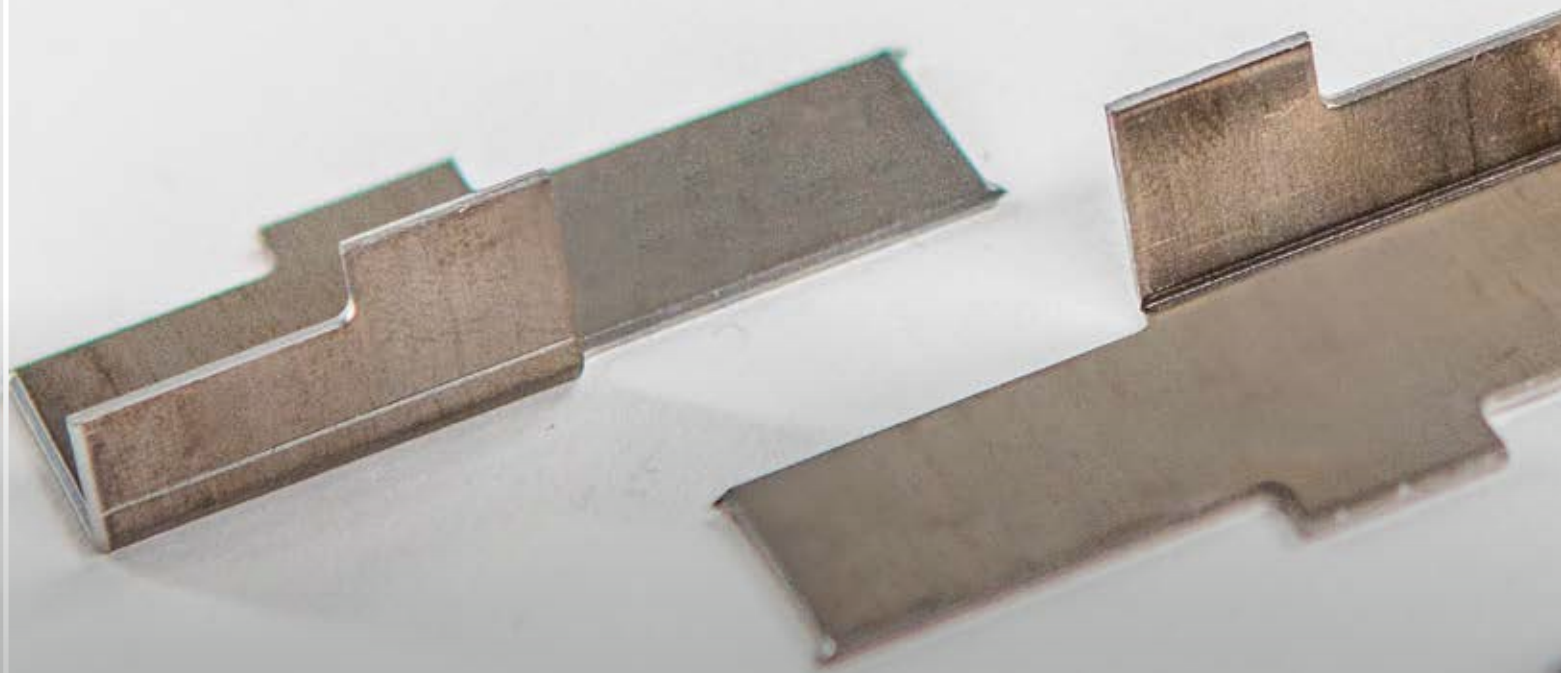

STRIPPING WITHOUT LOWER PINS. IT ALL DEPENDS ON THE CLAW.

Dynamic stripping. Without lower pins. With marbstrip claws.
The original. Only from Marbach. For maximum stripping performance.

www.marbach.com



MARBACH

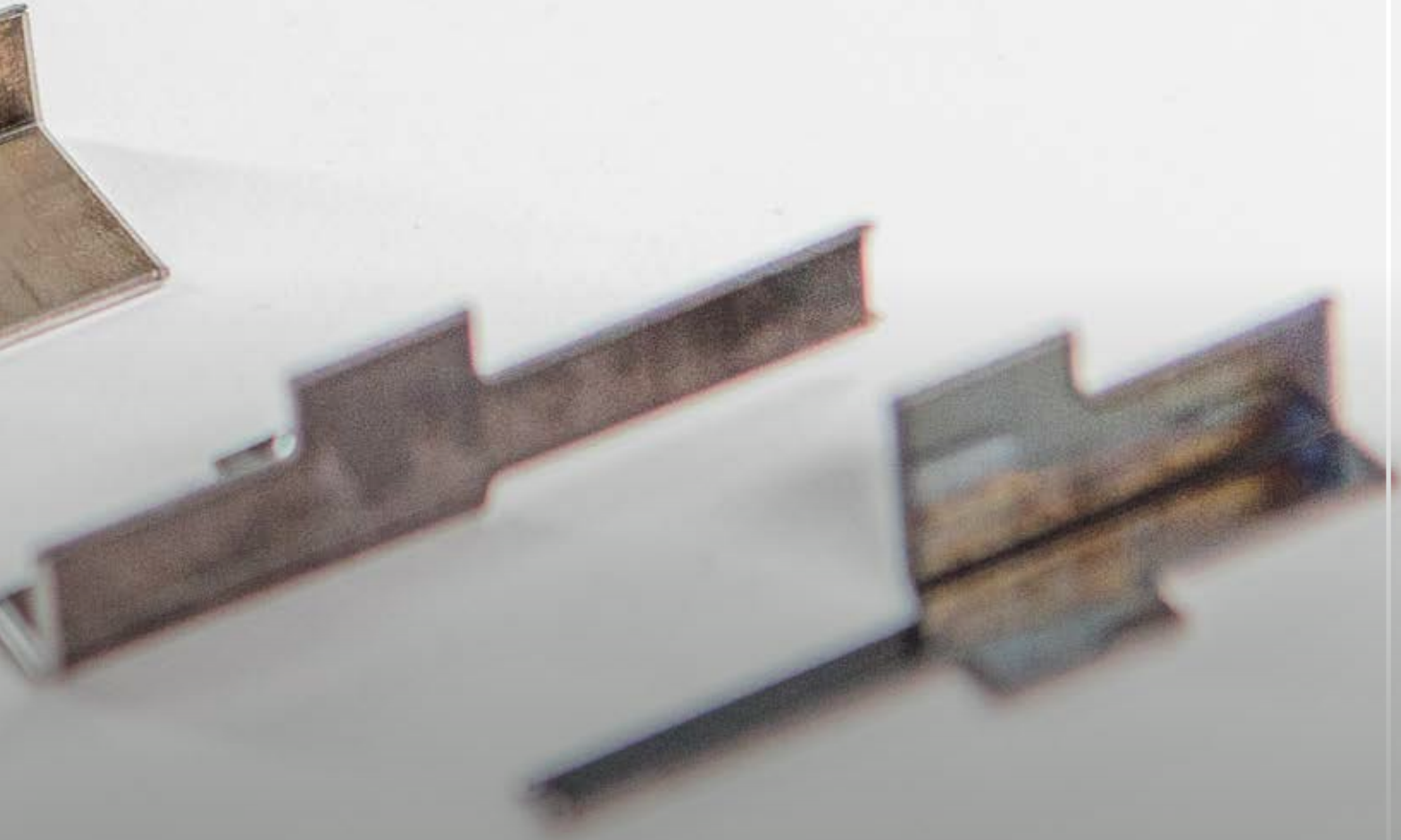

Marbach Group
Karl Marbach GmbH & Co. KG

Karl-Marbach-Straße 1
74080 Heilbronn
Germany
phone +49 7131 918-450
supplies@marbach.com
www.marbach.com

**PACKAGING.
PERFORMANCE.
YOU.**

Marbach reserves the right to make changes without prior notice.

(c) Marbach 2021

Stand 26.07.2021